

# Kaleido

*“ Per il mio gelato scelgo gli ingredienti migliori.  
Poi, ne esalto il gusto con un pizzico di carattere ”*

*“ I choose the finest ingredients for my gelato.  
Then I enhance the flavour with a bit of character ”*







# Kaleido

un design di carattere...

a design of character...

K  
a  
a  
i  
a  
a

...per una



# vetrina dalle prestazioni superiori.

...for a showcase featuring superior performance.



**Apparire.**

Con un design raffinato e funzionale, pensato, in ogni particolare, per esaltare la qualità dei prodotti. Come la vaschetta inclinata, che permette di mostrare angoli di visuale mai raggiunti. O i led, ideali per evidenziare l'assortimento e far risaltare agli occhi del cliente il gusto preferito.

**To appear.**

With a design both elegant and functional, well thought out in every detail, to enhance the quality of the products. Like the slanted basin, that shows off viewing angles never achieved before. Or the LEDs, ideal to highlight the assortment and attract the customer's eye right to his favourite flavour.

# Essere o apparire?

**Essere.**

Con una solidità che nasce dalla scelta di materiali di prima qualità come acciaio e vetro. Un'affidabilità che si riconosce e si tocca con mano. Ogni giorno. Questo è il carattere di Kaleido. La stoffa del fuoriclasse.

**To be.**

With a solidity that comes from choosing quality raw materials like steel and glass. A reliability you can recognise and touch with your hands. Every day. That is the character of Kaleido. The stuff of excellence.

La scelta è semplice: entrambi.

To be or to appear?  
The choice is easy: both.



# Iper **t**ecnologica. Decisamente.

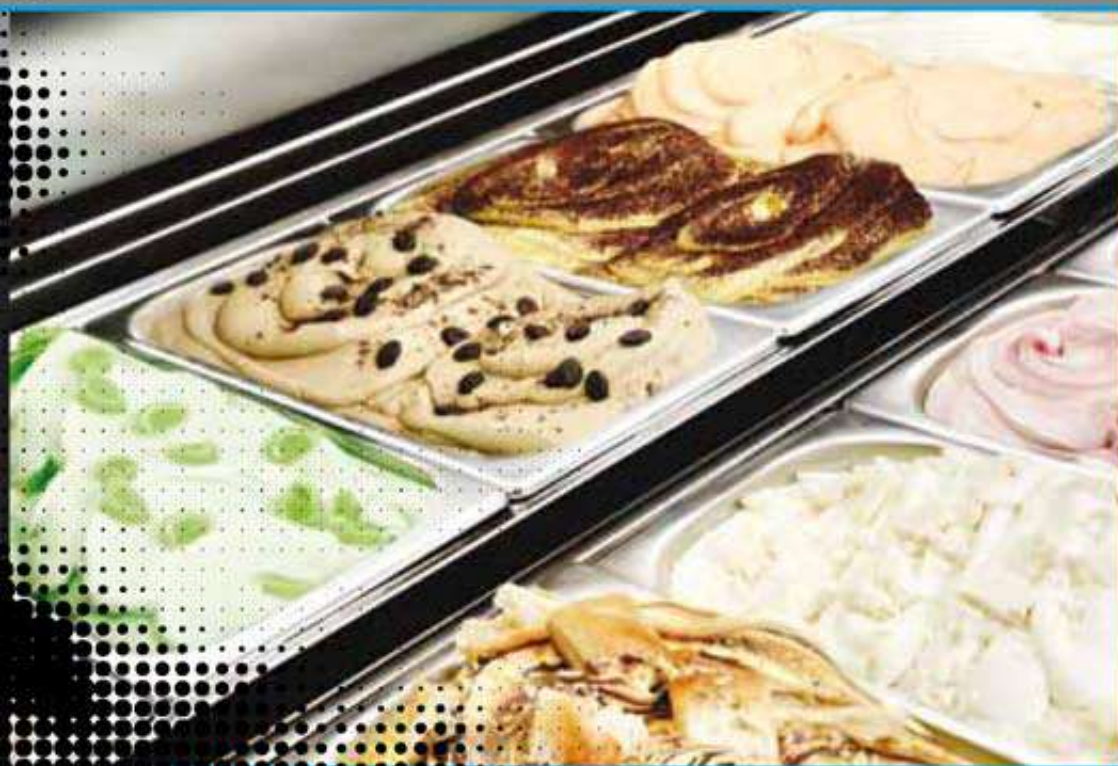

Refrigerazione ad aria ventilata a doppia mandata. Equalizzazione della temperatura. Alte performances del freddo, con vetri termicamente isolati; controllo elettronico automatico del set point quando la tendina è chiusa; sistema duty cycle a ciclo fisso per il controllo dell'antiappannamento dei vetri. Pianetto posteriore in Corian, per unire estetica, funzionalità, durata e igiene.

Hyper Technologic. Decidedly. Forced-air refrigeration with bifurcated fan. Temperature equalisation. High cold performance, with thermally insulated glass; automatic electronic control of the set point when the cover is closed; fixed-cycle duty cycle system for controlling clouding of the glass. Corian rear work surface combining beauty, functionality, long life and hygiene. Technology? That's not even the half of it.

**DIRE TECNOLOGIA È DAVVERO DIRE POCO.**





# Pasticceria.

Con stile.

Altezze studiate per assicurare massima visibilità. Mensole regolabili in profondità per muoversi con agilità tra pasticcini, torte e praline. Canalizzazione ideale per presentare ogni specialità nella maniera migliore. Refrigerazione mirata.

**Pastry. With style.** Heights designed to ensure maximum visibility. Depth-adjustable shelves for moving easily between pastries, cakes and pralines. Ideal channelling to present every speciality in the best possible way. Targeted refrigeration. Even in confectionery, Kaleido leaves its mark.



ANCHE NELLA PASTICCERIA, KALEIDO LASCIA IL SEGNO



**P**ersonalità.

**P**ersonalizzabile.

**PRENDI. UNISCI. ABBINI. COMIONI.  
CAMBI. AGGIUNGI. MODELLI.**

Mentre la plasmiamo al lay out del tuo locale, Kaleido mantiene intatta la propria personalità. Due altezze, per esaltare gelato, pasticceria e pralineria. Predisposizione per la movimentazione su ruote. Mensole regolabili in profondità per la pasticceria. Estrema versatilità: la temperatura può variare -20° a +5° nella vetrina gelateria per consentire il miglior utilizzo in ogni stagione. È un piacere vederla. È un piacere sceglierla. È un piacere personalizzarla.

**Personality. Customizable.** Even if you shape it to suit your shop layout, Kaleido keeps its own personality intact. Two heights, to show off gelato, pastries and pralines. Ready to be moved on wheels. Adjustable deep shelves for pastries. Extreme versatility. Temperature in gelato showcase can vary from -20° to +5° to allow the best possible use in every season. It is a pleasure to see. It is a pleasure to choose. It is a pleasure to customize. Take, combine, match, compose, change, add, shape.





# Pannello illuminato RGB (optional)

RGB lighted panel



Chinese Red Lacquer  
Painted Rear Glass

White Alicrite

ral 9005  
Black  
Painted  
Rear  
Glass

Ostrich  
Hide

## Front colours Colori frontali

- ..... Alicrite Colore Bianco (String Bride) .....
- ..... Vetro Retro Verniciato Lacca Rosso Cinese .....
- ..... Vetro Retro Verniciato Nero ral 9005 .....
- ..... Pelle di Struzzo .....

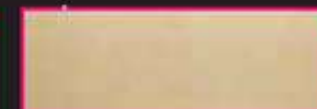
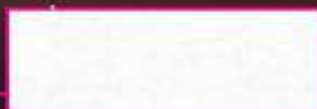

# e

ecologica.

## NATURALMENTE.

Kaleido ha le idee chiare per quanto riguarda il rispetto dell'ambiente: lo dimostra la scelta di materiali ecologici e della tecnologia (energy system) per garantire la massima efficienza energetica. Ad esempio, un evoluto sistema di refrigerazione rende possibile una significativa riduzione dei consumi. Mentre l'utilizzo del CO2 come elemento espandente nel poliuretano iniettato per l'isolamento termico, rappresenta la soluzione con il miglior rapporto tra eco-compatibilità e sicurezza.

**Eco-friendly.** Kaleido has clear ideas about respecting the environment: that shows up in the choice of eco-friendly materials and technology (energy system) to ensure maximum energy efficiency. For example, an evolved refrigeration system allows substantial energy savings. Using CO2 as expander element into the polyurethane injected as thermal insulation is the best solution in terms of eco-compatibility and safety. Naturally.





 **CO<sub>2</sub> 100%**  
Green generation



# Impeccabile. Sempre.



Con Kaleido, efficienza e praticità sono al servizio dell'igiene. L'apertura verso l'alto permette di effettuare tutte le operazioni quotidiane rapidamente e con precisione. Ogni angolo è accessibile. Ogni dettaglio visibile.

**Impeccable. Always.** Kaleido's efficiency and practicality in the service of hygiene. The upper opening allows to do all the daily operations quickly and accurately. Every corner is accessible. Every detail is visible. For a flawless hygiene.

PER UN'IGIENE IMPECCABILE



# caratteristiche tecniche

## Technical features

### Gelateria

- piano espositivo inclinato a 11°
- refrigerazione ventilata a doppia mandata dell'aria
- telaio castello vetri realizzato in acciaio lucido
- vetro frontale camera doppio riscaldato
- vetri fianchi camera doppi riscaldati
- apertura vetro frontale verso l'alto con pistoni servo assistiti
- chiusura lato operatore con tendina
- illuminazione solo led
- sbrinatorio ad inversione di ciclo
- classe 4+ (35°C/70% RH)
- frontale disponibile in: acrilite bianco, pelle di struzzo, vetro retro verniciato nero e rosso

### Promotional Ice Cream

- display surface at 11° inclined
- forced-air refrigeration with bifurcated fan
- glass mounting frame in polished steel
- double-heated front glass
- double-heated side glass
- frontal glass opening upward with power-assisted pistons
- operator-side closure with cover
- LED-only lighting
- cycle-inversion defrosting
- class 4+ (35°C/70% RH)
- front available in: white acrilite, ostrich skin, rear glass painted black and red

### Pasticceria

- piano espositivo inclinato a 4°
- refrigerazione ventilata
- telaio castello vetri realizzato in acciaio lucido
- mensole regolabili in profondità refrigerate
- due mensole per l'altezza h135
- una mensola per l'altezza h117
- vetro frontale camera doppio
- vetri fianco camera doppi
- apertura vetro frontale verso l'alto con pistoni servo assistiti
- chiusura lato operatore con tendina
- illuminazione solo led
- sbrinatorio a fermata compressore
- classe climatica 3 (25°C/60% RH)

### Pastry

- display surface at 4° inclined
- forced-air refrigeration
- glass mounting frame in polished steel
- refrigerated depth-adjustable shelves
- two shelves h135
- one shelf h117
- double frontal glass
- double side glass
- frontal glass opening upward with power-assisted pistons
- operator-side closure with cover
- LED-only lighting
- stop-compressor defrosting
- climate class 3 (25°C/60% RH)

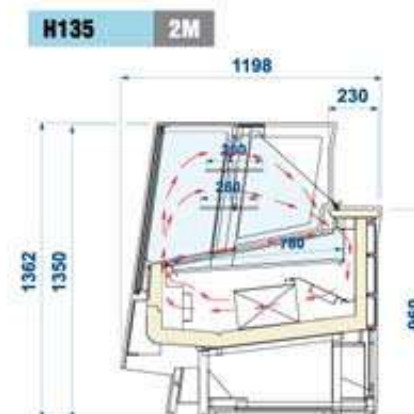
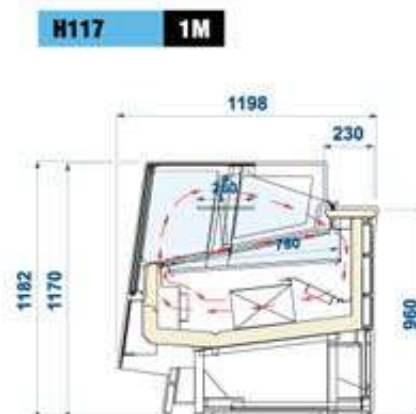
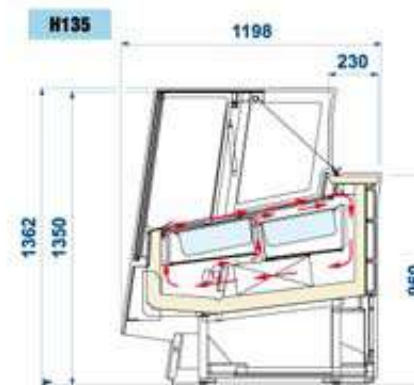
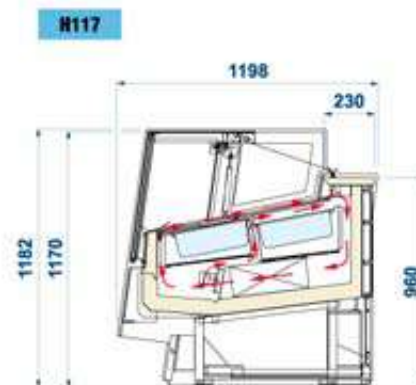

# Gelateria

## Promotional Ice Cream

KALEIDO

H117



H135



120

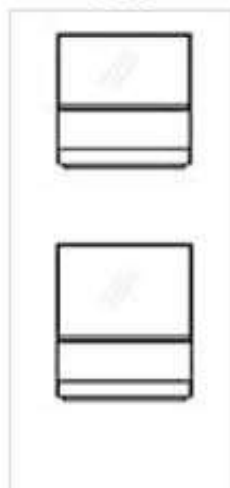

RV

170

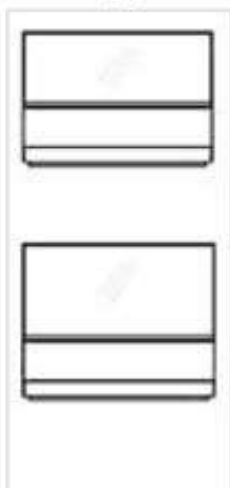

RV

220

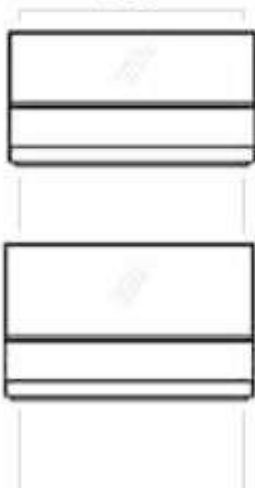

RV

AE 45



RV

170 (120+50)

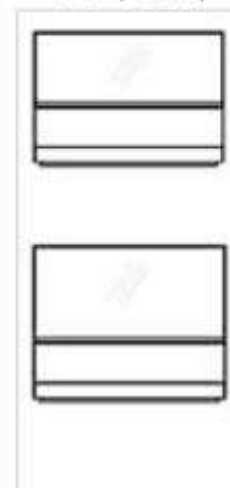

RV

220 (170+50)



RV

Dimensioni esterne (lpxh)  
External dimensions (lxdxh)

mm	<b>H117</b>	1182 x 1198 x 1170	1677 x 1198 x 1170	2172 x 1198 x 1170	1875 x 1198 x 1170	1677 x 1198 x 1170	2172 x 1198 x 1170
mm	<b>H135</b>	1182 x 1198 x 1350	1677 x 1198 x 1350	2172 x 1198 x 1350	1875 x 1198 x 1350	1677 x 1198 x 1350	2172 x 1198 x 1350

Refrigerazione  
Refrigeration

		Ventilata Ventilated	Ventilata Ventilated	Ventilata Ventilated	Ventilata Ventilated	Ventilata Ventilated	Ventilata Ventilated
--	--	-------------------------	-------------------------	-------------------------	-------------------------	-------------------------	-------------------------

Capacità (lorda - netta)  
Capacity (gross - net)

lit.	<b>H117</b>	685 / 147	1009 / 216	1332 / 285	901 / 193	1009 / 216	1332 / 285
lit.	<b>H135</b>	824 / 147	1212 / 216	1600 / 285	1082 / 193	1212 / 216	1600 / 285

Temperatura di regolazione  
Cabinet capacity range

°C		-20 / +2	-20 / +2	-20 / +2	-20 / +2	-20 / +2	-20 / +2
----	--	----------	----------	----------	----------	----------	----------

Temperatura prodotto  
Product temperature

°C		-16 / -14	-16 / -14	-16 / -14	-16 / -14	-16 / -14	-16 / -14
----	--	-----------	-----------	-----------	-----------	-----------	-----------

Sbrinamento  
Defrost

		Inversione ciclo Reverse Cycle	Inversione ciclo Reverse Cycle	Inversione ciclo Reverse Cycle	Inversione ciclo Reverse Cycle	Inversione ciclo Reverse Cycle	Inversione ciclo Reverse Cycle
--	--	-----------------------------------	-----------------------------------	-----------------------------------	-----------------------------------	-----------------------------------	-----------------------------------

Classe climatica  
Climatic class

N°		4+	4+	4+	4+	4+	4+
----	--	----	----	----	----	----	----

Condizioni ambientali  
Operating conditions

°C / %RH		35 / 70	35 / 70	35 / 70	35 / 70	35 / 70	35 / 70
----------	--	---------	---------	---------	---------	---------	---------

Compressore (Tipo - n°)  
Compressor (Type - n°)

		Ermetico 1 Hermetic 1	Ermetico 2 Hermetic 2	Ermetico 2 Hermetic 2	Ermetico 2 Hermetic 2	Ermetico 2 Hermetic 2	Ermetico 2 Hermetic 2
--	--	--------------------------	--------------------------	--------------------------	--------------------------	--------------------------	--------------------------

Alimentazione  
Power supply

V / ph / Hz		230 / 1 / 50	400 / 3 / 50	400 / 3 / 50	400 / 3 / 50	400 / 3 / 50	400 / 3 / 50
-------------	--	--------------	--------------	--------------	--------------	--------------	--------------

Assorbimento elettrico (regime)  
Electrical input (standard)

W / A		1240 / 6	1510 / 2,3	2350 / 3,6	1510 / 2,3	1510 / 2,3	2350 / 3,6
-------	--	----------	------------	------------	------------	------------	------------

Assorbimento elettrico (sbrinamento)  
Electrical input (defrost)

W / A		2300 / 11	2560 / 6,2	3890 / 9,4	2560 / 6,2	2560 / 6,2	3890 / 9,4
-------	--	-----------	------------	------------	------------	------------	------------

Peso netto  
Net weight

kg	<b>H117</b>	320	409	510	400	409	510
kg	<b>H135</b>	346	434	535	425	434	535

H117

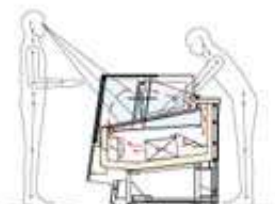

H135

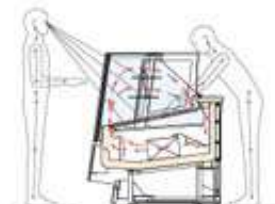

120

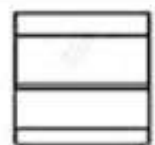

RV

170

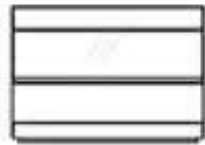

RV

220

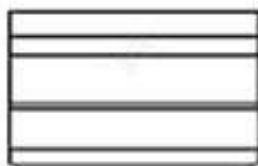

RV

AE 45



RV

Dimensioni esterne (lxpxh)  
External dimensions (lxpxh)

mm	<b>H117</b>	1182 x 1198 x 1170	1677 x 1198 x 1170	2172 x 1198 x 1170	1875 x 1198 x 1170
mm	<b>H135</b>	1182 x 1198 x 1350	1677 x 1198 x 1350	2172 x 1198 x 1350	1875 x 1198 x 1350

Refrigerazione  
Refrigeration

		Ventilata Ventilated	Ventilata Ventilated	Ventilata Ventilated	Ventilata Ventilated
--	--	-------------------------	-------------------------	-------------------------	-------------------------

Capacità (lorda - netta)  
Capacity (gross - net)

ℓ	<b>H117</b>	685 / 267	1009 / 393	1332 / 518	901 / 193
ℓ	<b>H135</b>	824 / 267	1212 / 393	1600 / 518	1082 / 193

Temperatura prodotto  
Product temperature

°C		+1 / +10	+1 / +10	+1 / +10	+1 / +10
----	--	----------	----------	----------	----------

Sbrinamento  
Defrost

		Fermata Compressore Stop Compressor	Fermata Compressore Stop Compressor	Fermata Compressore Stop Compressor	Fermata Compressore Stop Compressor
--	--	--	--	--	--

Classe climatica  
Climatic class

N°		3	3	3	3
----	--	---	---	---	---

Condizioni ambientali  
Operating conditions

°C / %RH		25 / 60	25 / 60	25 / 60	25 / 60
----------	--	---------	---------	---------	---------

Compressore (Tipo - n°)  
Compressor (Type - n°)

		Ermetico 1 Hermetic 1	Ermetico 1 Hermetic 1	Ermetico 1 Hermetic 1	Ermetico 1 Hermetic 1
--	--	--------------------------	--------------------------	--------------------------	--------------------------

Alimentazione  
Power supply

V / ph / Hz		230 / 1 / 50	230 / 1 / 50	230 / 1 / 50	230 / 1 / 50
-------------	--	--------------	--------------	--------------	--------------

Assorbimento elettrico (regime)  
Electrical input (standard)

W / A		1360 / 7,4	1485 / 8,1	1610 / 8,7	1360 / 7,4
-------	--	------------	------------	------------	------------

Assorbimento elettrico (sbrinamento)  
Electrical input (defrost)

W / A		420 / 2,3	485 / 2,6	450 / 2,4	420 / 2,3
-------	--	-----------	-----------	-----------	-----------

Peso netto  
Net weight

kg	<b>H117</b>	320	409	510	400
kg	<b>H135</b>	346	434	535	425

# A ccessori

Accessories

## Porta Monoporzioni

Single-serving holder



## Segnagusti

Flavour labels

## Ruote Pivottanti

Pivoting wheels



## Porta Coni

Cone Holder



## Porta Stecchi

Stick holder

## Vassoio Torta in Acciaio INOX

SS Cake Tray



## Contenitore Carta Lamiera Verniciata a Polvere

Powder Coated Paper Holder



Vaschetta Trapezoidale

Trapezoidal Basin



Vaschetta 36x16,5

Basin 36x16,5



Vaschetta 36x25

Basin 36x25



Lavaporzionatore

Server Sink



*Idee che lavorano con te*

ISA S.r.l. Via del Lavoro, 5  
06083 Bastia Umbra (Pg) - Italy  
tel +39 075 80171  
fax +39 075 8017304  
[www.isaitaly.com](http://www.isaitaly.com)



Kaleido è un progetto ISA R&D e **polipodesign**

428100097000-01-2012