

# RHENINGHAUS

CATALOGUE EDITION 2014/2015

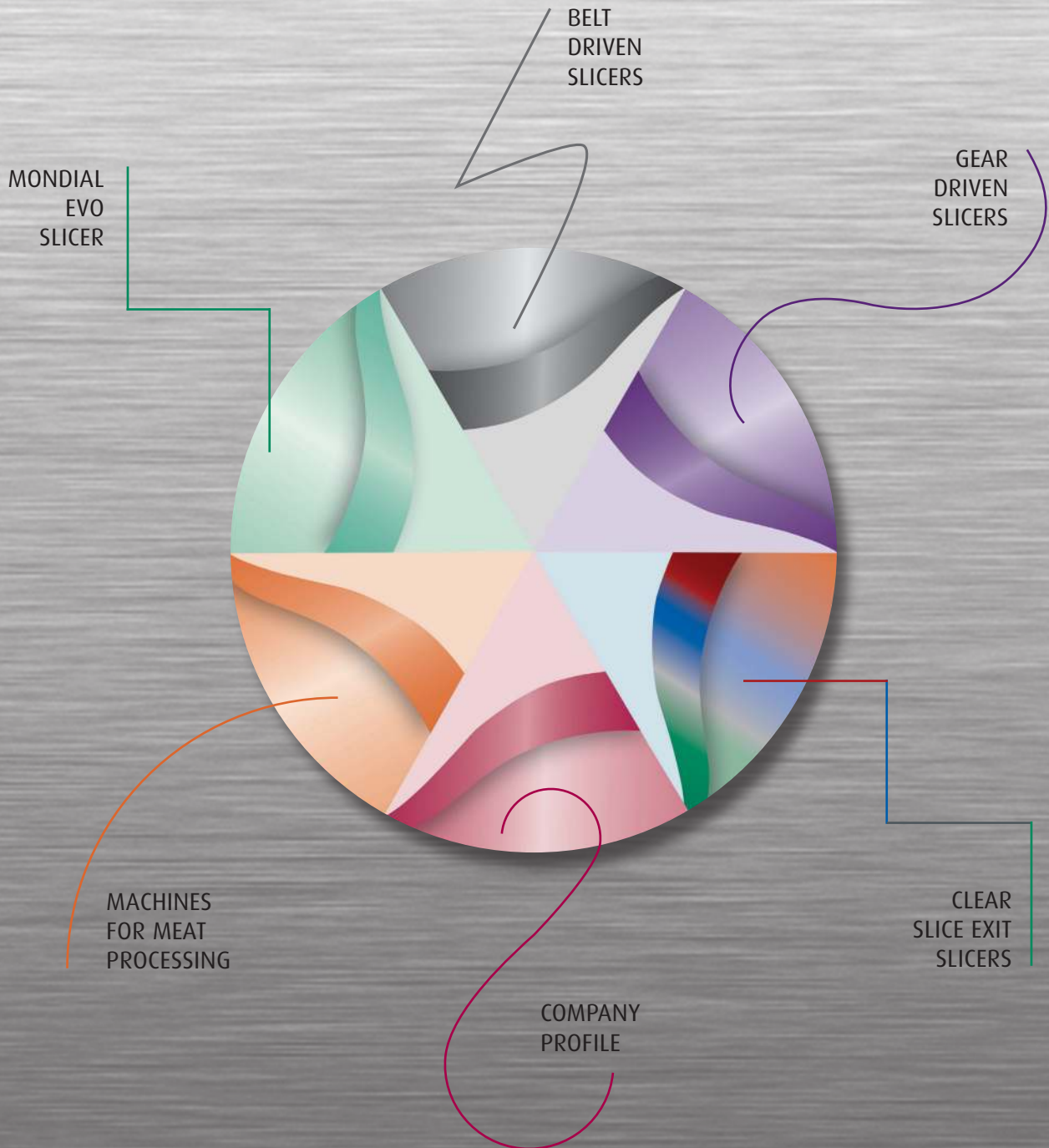

FOOD PREPARATION MACHINES

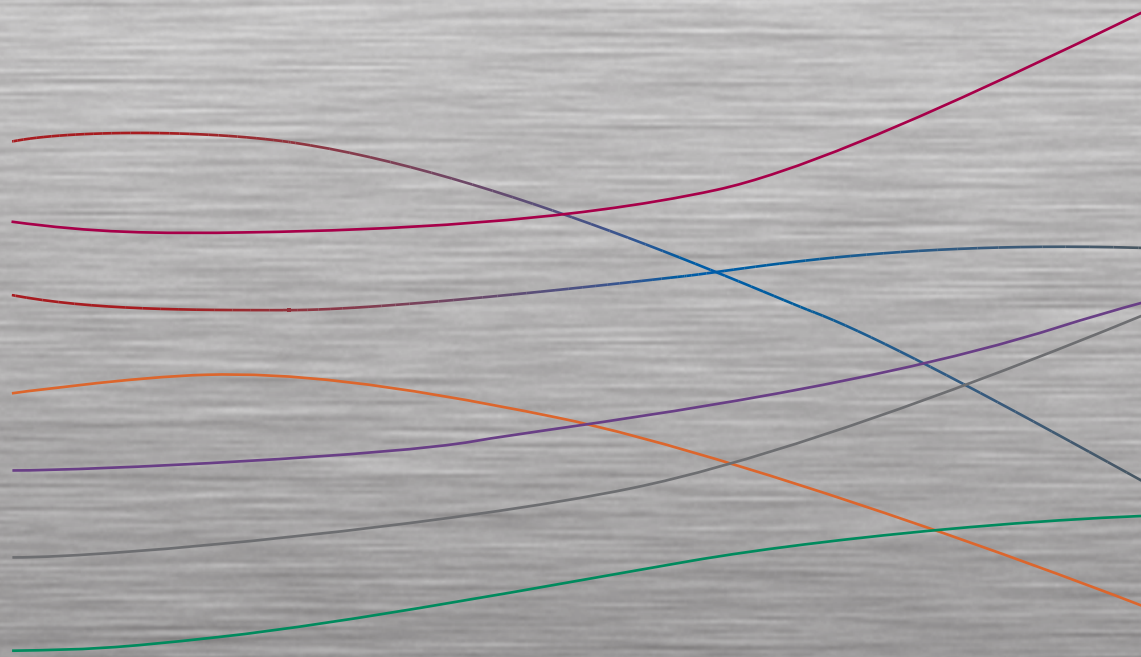



## CONTENTS

RHENINGHAUS COMPANY PROFILE	2
-----------------------------	---

### **BELT DRIVEN SLICERS**

START-L 220/250/300	5
START 300/350	6
START AUTO 300/350 <b>SBR</b>	8

### **GEAR DRIVEN SLICERS**

SUPER START 300 - SUPER START 350 ECO	12
SUPER START 350	14
SUPER START AUTO 300 <b>SBR</b>	16
SUPER START AUTO 350 <b>SBR</b>	18

### **CLEAR SLICE EXIT SLICERS**

PRIMA 250/300	22
MONDIAL 300/350 <b>SBR</b>	24

### **MONDIAL EVO SLICER**

27

### **CLEAR SLICE EXIT VERTICAL SLICERS**

BETA BN 300/350 <b>SBR</b>	30
BETA BS 300/350 <b>SBR</b>	32

OPTIONALS LIST	34
----------------	----

### **MACHINES FOR MEAT PROCESSING**

VELOX SBR M/VELOX <b>SBR</b> L	38
FAST 100/130	39
EVE/ALL-12 • EVE/ALL-22	40
EVE/2000-12 • EVE/2000-22	41
SATURNO 22 • LABOR 32	42
PRIMA Gourmet 3/5	43
EVE/ALL-G12/G22 • EVE/2000-G12/G22	44

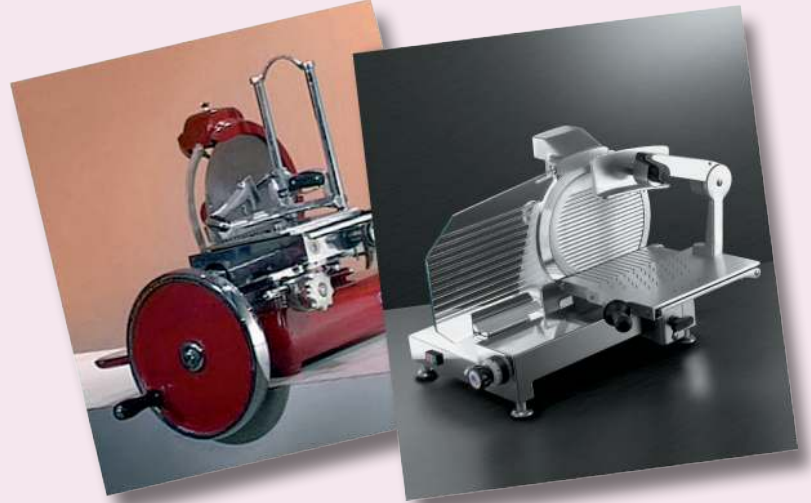
**COMPANY PROFILE**

RHENINGHAUS is one of the leading names in Italy since 1950 in the design, development and manufacturing of a wide range of Professional Machines for the catering and food industry such as Slicers, Meat Mincers, Bone-Saws, Cutters, etc...

Our activity embraces the whole production cycle, including design, casting of aluminium parts, mechanical machining, assembly, packing and forwarding.

Our variety is the most assorted and complete one and it's easily adaptable to the various international market requirements: the 98% of our sales is exported and therefore we know and fulfill the most different requirements thus combining the quality level required by the most demanding markets with a competitive price.

We have matured particular experience in the catering and distribution sectors of which we know all specific problems:

- humidity, heat, sudden changes in temperature
- rough and not much professional personnel
- not conventional machine washing and cleaning systems
- poor maintenance.

Present catalogue shows the complete range that includes:

- slicers: belt or gear driven, gravity or vertical, manual or automatic, anodized or QuanTanium coated: from page 5 to page 32,
- various machines for meat and food processing: from page 38 to page 44.

**"A strong yet innovative tradition"**

Original projects based on our vast experience, designed with creativeness and with customers' feedback and requirements in mind.

**"A solution for every need"**

Our professional machines are designed to meet the widest range of food preparation needs. Our range includes models suited to the limited spaces of coffee bars, belt or gear versions, different solutions for specific products (meat, bread, cheese, vegetables, fish and frozen products), high resistance to humidity.

**"Sturdy and high performing workmates"**

Powerful motors designed for continuous use; premium quality European components; electric parts resistant to humidity and insects; precision mechanical machining and accurate assembling.

**"Uncompromised safety"**

All our machines have a CE marking in compliance with European Standards and therefore guarantee the utmost safety. Our ergonomic and practical cleaning solutions are specifically designed to simplify cleaning and prevent all possible risks.

**"Hygiene: an effective pit-stop"**

Compliance with the international CE and NSF Standards. Our innovative solutions simplify cleaning and reduce potential risks. All our machines are supplied with a bottle of FAST CLEANER, a detergent/sanitizer specifically designed for food preparation machines.



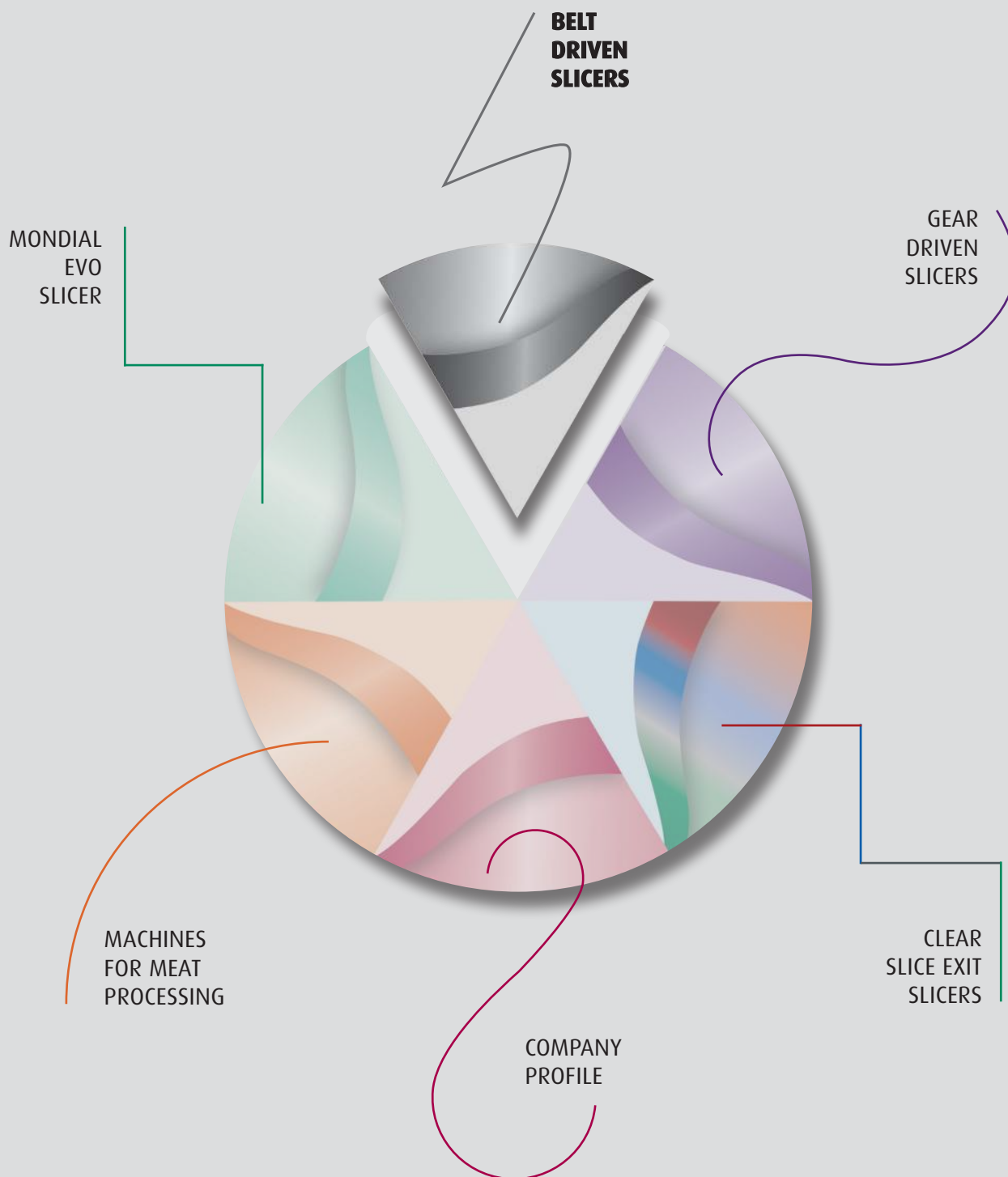

**Belt Drive:** noiseless and economical transmission. Life of our Multygrip belts is remarkable. The constant grip is helped by gaskets against moisture.



START 300/350



START AUTO 300/350 SBR



START - L 220/250/300



**DESCRIPTION**

START-L is a precision compact slicer: the best quality in a small size. Classic design, all metal parts, superior performance. Professional components and fine tuning make the difference! Ideal for coffee shops and small restaurants: not suited for supermarkets and big restaurants.

**FEATURES**

Three available sizes: with 220mm or 250mm or 300mm blade. Anodized aluminium casting construction: sturdy and light weight. High quality hardened chromium steel alloy blade. Powerful and noiseless motor. Insulated electric controls with safety **No Volt Release**. Multygrip belt drive: always the right grip. Carriage smooth glide motion. Slice thickness precision adjustment: gasket-sealed mechanism. Drip deflecting edge of the gauge plate: adjustment mechanism is protected. Stainless steel ball-bearing blade pulley. Built-in sharpener, removable for cleaning purposes. International homologations



**STANDARD OUTFIT**



User Manual, CE compliance declaration and "TEN BASIC RULES" Cardboard.







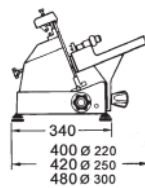
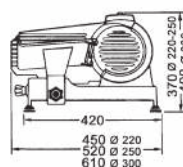







FAST CLEANER detergent, Cleaning nylon brush, Oiler.

**DIMENSIONS**



**SPECIFICATIONS AND SHIPPING INFORMATION**

						
Model name	Blade mm	Power Hp/kW	Drive	Cut Capacity mm	Cut thick. mm	Net weight kg
<b>Start-L 220</b>	220	0,15/0,11	BELT	 210x135  220	13	13
<b>Start-L 250</b>	250	0,25/0,18	BELT	 210x150  250	13	16
<b>Start-L 300</b>	300	0,25/0,18	BELT	 240x190  300	13	19

**SHIPPING**

Dimension	Weight
cm 54x46x41	16 kg
cm 62x55x45	20 kg
cm 74x60x56	23 kg

All voltages and frequencies are available on request.

**DESCRIPTION**

START is a powerful slicer with great quality/price ratio.

This handy and sturdy machine is the best solution when safety and hygiene are main priorities.

The special protections make it suited for humid environments.

Ideal for deli shops, supermarkets, restaurants, hotels, catering companies.

**FEATURES**

Two available sizes: with 300 mm or 350 mm blade.  
Anodized aluminium casting construction: sturdy and light weight.

High quality hardened chromium steel alloy blade.

Powerful and noiseless continuous use motor.

Insulated switch with safety **No Volt Release**.

Multygrip belt drive: always the right grip.

Carriage smooth glide motion also with heavy products.

Large clearance between the back of the blade and the base provides access for easy cleaning (pict. **1**).

Slice thickness precision adjustment: gasket-sealed mechanism (pict. **2**).



Drip deflecting edge of the gauge plate: adjustment mechanism is protected (pict. **3**).

No-drip edge base: easy cleaning (pict. **4**).

Stainless steel ball-bearing blade pulley and special moisture-proof gasket.

Built-in sharpener, removable for cleaning purposes (pict. **5**).

30° carriage angle: good visibility of the slice exit area and better ergonomy.

International homologations   



# MANUAL GRAVITY SLICER BELT DRIVEN

Model  
**START 300/350**

Large clearance between blade and base.  
High protection against moisture

Carriage smooth glide motion

Powerful and noiseless motor

Sturdy construction for precise slices

Wide slice exit area with no-drip profile

Thickness adjustment: gasket-sealed mechanism

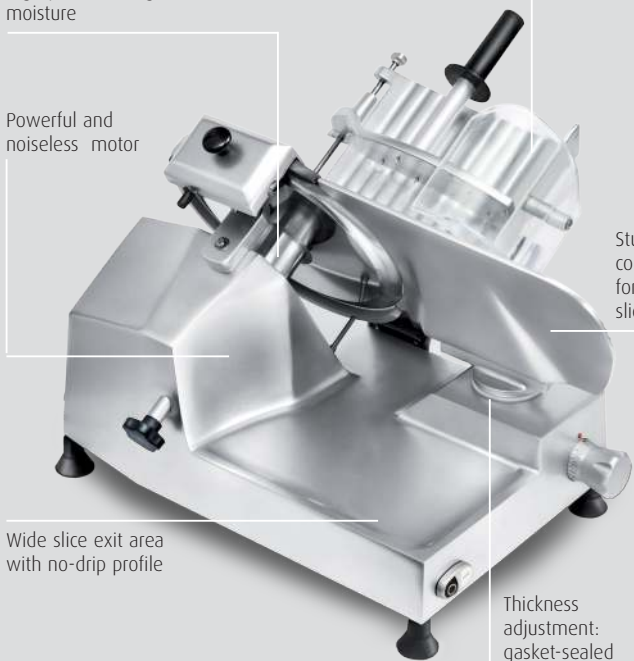

## AVAILABLE CONFIGURATIONS ANODIZED



All external aluminium parts are silver anodized: *TRADITIONAL SILVER FINISHING.*

## BASIC QUANTANIUM



Gauge plate, blade and blade cover disc are non-stick coated. Remaining aluminium parts are anodized: *CHEESE CUTTING IS NO MORE A PROBLEM.*

## TOTAL QUANTANIUM



All external aluminium parts are black Quantanium non-stick coated to be resistant to all detergents: *THE BLACK APPEAL.*

## STANDARD OUTFIT



User Manual, CE compliance declaration and "TEN BASIC RULES" Cardboard.



FAST CLEANER detergent, Cleaning nylon brush, Oiler.



Quantanium® with Titanium particles reinforced three-layer non-stick coating will allow:  
● smoothness: difficult products

like cheese or fresh meat do not stick and products slide smoothly and frictionless;

- higher resistance to abrasion;
- resistance to most aggressive detergents.

## AVAILABLE OPTIONS



**SBR** (Safe Blade Removal): it allows for quick and safe removal of the blade during slicer cleaning.



Non stick coated blade, perfect for cheese and fish cutting. Already included in Quantanium® configuration.



Serrated blade for frozen food cutting.



Stainless steel chute for vegetable cutting.



Inclined product holder. Easy to assemble, no tools needed.



**ES** (Energy saver): drastically reduces power consumption.

## DIMENSIONS

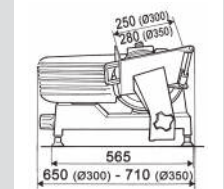
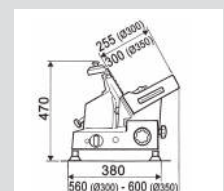

## SPECIFICATIONS AND SHIPPING INFORMATION

Model name	Blade mm	Power Hp/kW	Drive	Cut Capacity mm	Cut thick. mm	Net weight kg
<b>START 300</b>	300	0,35/0,25	Belt	240x160 ○ 190	20	29
<b>START 350</b>	350	0,35/0,25	Belt	280x190 ○ 220	20	32

All voltages and frequencies are available on request.



## SHIPPING

Dimension	Weight
cm 74 x 58 x 56	35 kg
cm 79 x 64 x 58	39 kg

**DESCRIPTION**

START AUTO SBR is a powerful automatic slicer that can also be used manually. Sturdy and high performing: carriage speed selection from 0 up to 60 slices/min. Easy to use, easy to clean. Ideal for supermarkets, restaurants, catering companies, laboratories.

**FEATURES**

Two available sizes: with 300 mm or 350 mm blade.  
Anodized aluminium casting construction: sturdy and light weight.  
High quality hardened chromium steel alloy blade.  
Powerful and noiseless continuous use motor.  
Multygrip belt drive: always the right grip.  
Special product holder with adjustable fence and three-position heavy food pusher.  
Large clearance between the back of the blade and the base provides access for easy cleaning (pict. 1).  
Slice thickness precision adjustment: gasket-sealed mechanism (pict. 2).  
Drip deflecting edge of the gauge plate: adjustment mechanism is protected (pict. 3).  
No-drip edge base: easy cleaning (pict. 4).  
Stainless steel ball-bearing blade pulley and special moisture-proof gasket.  
Equipped with **SBR** (Safe Blade Removal) (pict. 5).  
Built-in sharpener, removable for cleaning purposes: simple and convenient.  
30° carriage angle: good visibility of the slice exit area and better ergonomy.  
International homologations   



# AUTOMATIC GRAVITY SLICER BELT DRIVEN

Model  
**START AUTO 300/350 SBR**

Large clearance between blade and base.  
High protection against moisture

Powerful and noiseless motor

Wide slice exit area with no-drip profile

Adjustable fence and three-position heavy food pusher

Sturdy construction for precise slices

Thickness adjustment: gasket-sealed mechanism



## AVAILABLE CONFIGURATIONS

### ANODIZED



All external aluminium parts are silver anodized: *TRADITIONAL SILVER FINISHING.*

### BASIC QUANTANIUM



Gauge plate, blade and blade cover disc are non-stick coated. Remaining aluminium parts are anodized: *CHEESE CUTTING IS NO MORE A PROBLEM.*

### TOTAL QUANTANIUM



All external aluminium parts are black Quantanium non-stick coated to be resistant to all detergents: *THE BLACK APPEAL.*

## STANDARD OUTFIT



**SBR** Safe Blade Removal

## AVAILABLE OPTIONS



Non stick coated blade, perfect for cheese and fish cutting. Already included in **Quantanium®** configuration.



**Quantanium®** with Titanium particles reinforced three-layer non-stick coating will allow:  
● smoothness: difficult products

like cheese or fresh meat do not stick and products slide smoothly and frictionless;

- higher resistance to abrasion;
- resistance to most aggressive detergents.



User Manual, CE compliance declaration and "TEN BASIC RULES" Cardboard.



**FAST CLEANER** detergent, Cleaning nylon brush, Oiler.







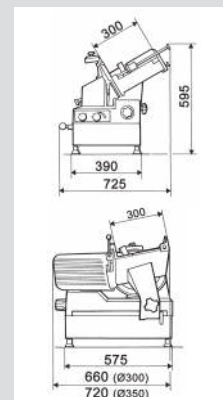

Stainless steel chute for vegetable cutting.



## DIMENSIONS



## SPECIFICATIONS AND SHIPPING INFORMATION

						
Model name	Blade mm	Power Hp/kW	Drive	Cut Capacity mm	Cut thick. mm	Net weight kg
<b>START AUTO 300 SBR</b>	300	0,48/0,37	Belt	285x165 ○ 190	20	43
<b>START AUTO 350 SBR</b>	350	0,48/0,37	Belt	280x190 ○ 220	20	45

All voltages and frequencies are available on request.

## SHIPPING

Dimension	Weight
cm 83 x 73 x 71	50 kg
cm 83 x 73 x 71	52 kg

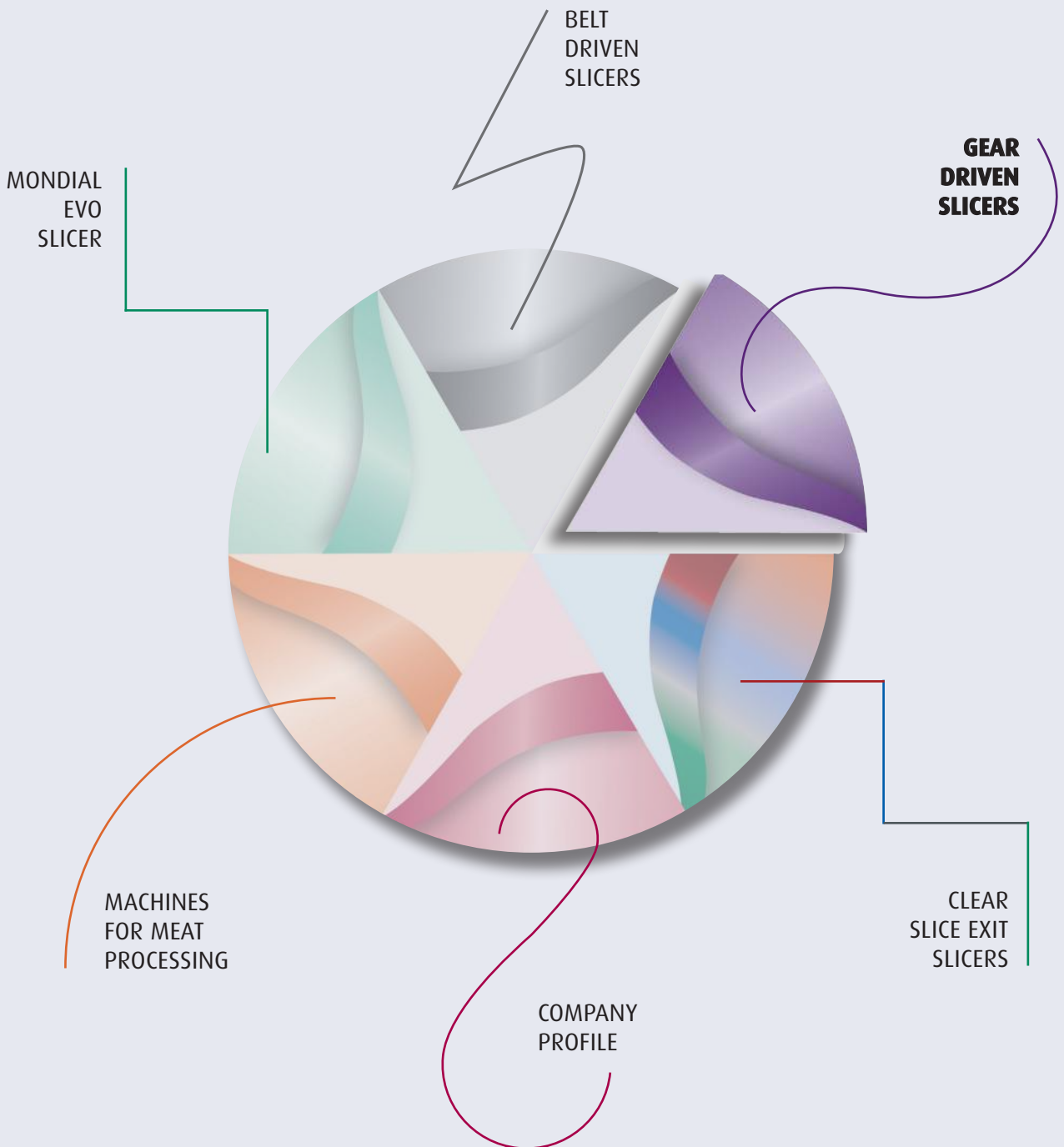

**Gear drive with electric fan:** powerful and maintenance-free transmission. It guarantees maximum power when cheese, frozen or hard products are sliced.



**SUPER START  
AUTO 350 SBR**

**SUPER START  
300/350 ECO**

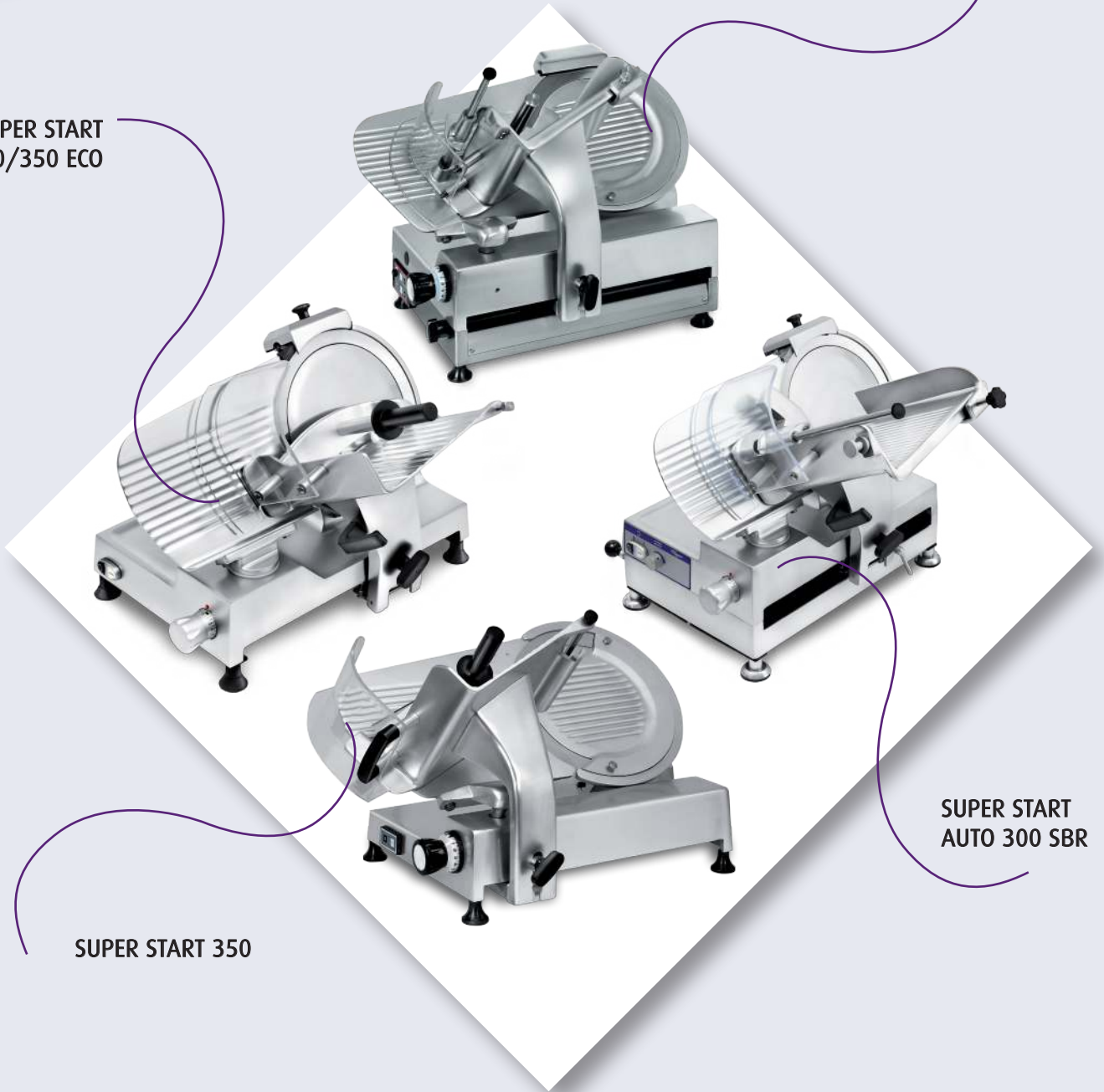

**SUPER START  
AUTO 300 SBR**

**SUPER START 350**



**SUPER START 300 / SUPER START 350 ECO**





**DESCRIPTION**

SUPER START is a powerful slicer with great quality/price ratio. This handy and sturdy machine is the best solution when safety and hygiene are main priorities. The special protections make it suited for humid environments. Ideal for deli shops, supermarkets, restaurants, hotels, catering companies. Gear drive guarantees maximum power when cheese, frozen or hard products are sliced.

**FEATURES**

Two available sizes: with 300 mm or 350 mm blade.  
Anodized aluminium casting construction: sturdy and light weight.  
High quality hardened chromium steel alloy blade.  
Powerful and noiseless continuous use motor.  
Insulated switch with safety **No Volt Release**.  
Gear drive: long life, no maintenance (pict. 1).  
Carriage smooth glide motion also with heavy products.  
Large clearance between the back of the blade and the base provides access for easy cleaning (pict. 2).  
Slice thickness precision adjustment: gasket-sealed mechanism (pict. 3).  
Drip deflecting edge of the gauge plate: adjustment mechanism is protected (pict. 4).  
No-drip edge base: easy cleaning (pict. 5).  
Stainless steel ball-bearing blade pulley and special moisture-proof gasket.  
Built-in sharpener, removable for cleaning purposes.  
30° carriage angle: good visibility of the slice exit area and better ergonomoy.

International homologations   



**MANUAL GRAVITY SLICER**  
GEAR DRIVEN

Model  
**SUPER START 300 / SUPER START 350 ECO**

Large clearance between blade and base.  
High protection against moisture

Carriage smooth glide motion

Powerful motor with maintenance-free gear drive

Sturdy construction for precise slices

Wide slice exit area with no-drip profile

Thickness adjustment: gasket-sealed mechanism

**STANDARD OUTFIT**



User Manual, CE compliance declaration and "TEN BASIC RULES" Cardboard.



FAST CLEANER detergent, Cleaning nylon brush, Oiler.

**AVAILABLE CONFIGURATIONS**

**ANODYZED**



All external aluminium parts are silver anodized: *TRADITIONAL SILVER FINISHING.*

**BASIC QUANTANIUM**



Gauge plate, blade and blade cover disc are non-stick coated. Remaining aluminium parts are anodized: *CHEESE CUTTING IS NO MORE A PROBLEM.*

**TOTAL QUANTANIUM**



All external aluminium parts are black Quantanium non-stick coated to be resistant to all detergents: *THE BLACK APPEAL.*



Quantanium® with Titanium particles reinforced three-layer non-stick coating will allow:  
● smoothness: difficult products

like cheese or fresh meat do not stick and products slide smoothly and frictionless;  
● higher resistance to abrasion;  
● resistance to most aggressive detergents.

**AVAILABLE OPTIONS**



**SBR** (Safe Blade Removal): it allows for quick and safe removal of the blade during slicer cleaning.



Non stick coated blade, perfect for cheese and fish cutting. Already included in Quantanium® configuration.



Serrated blade for frozen food cutting.



Stainless steel chute for vegetable cutting.



Inclined product holder. Easy to assemble, no tools needed.



Accessories holding rack

**DIMENSIONS**

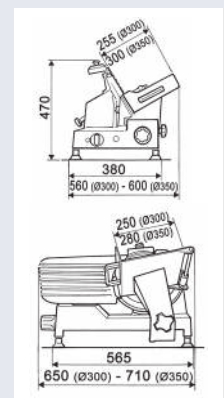

**SPECIFICATIONS AND SHIPPING INFORMATION**

Model name	Blade mm	Power Hp/kW	Drive	Cut Capacity mm	Cut thick. mm	Net weight kg
<b>SUPER START 300</b>	300	0,35/0,25	Gear	240x160 ○ 190	20	29
<b>SUPER START 350 ECO</b>	350	0,35/0,25	Gear	280x190 ○ 220	20	32

All voltages and frequencies are available on request.

**SHIPPING**

Dimension	Weight
cm 74 x 58 x 56	35 kg
cm 79 x 64 x 58	39 kg

**DESCRIPTION**

SUPER START 350 is a 45° gravity slicer. Solid and overdimensioned unit that guarantees top performances in its category. Ideal for high volume work load in super and hyper-markets and for products size up to 250 mm diameter. Gear drive guarantees maximum power when cheese, frozen or hard products are sliced.

**FEATURES**

Anodized aluminium casting construction: sturdy and light weight.  
High quality 350mm hardened chromium steel alloy blade.  
Powerful and noiseless continuous use motor.  
Insulated electric controls with safety **No Volt Release**.  
Gear drive: long life, no maintenance.  
Carriage smooth glide motion also with heavy products.  
Generously sized for top performances and easy cleaning (pict, **1** and **2**).  
Elegant design for a slicer that can't pass unnoticed.  
Build-in sharpener (pict. **3**).



**MANUAL GRAVITY SLICER**  
GEAR DRIVEN

Model  
**SUPER START 350**

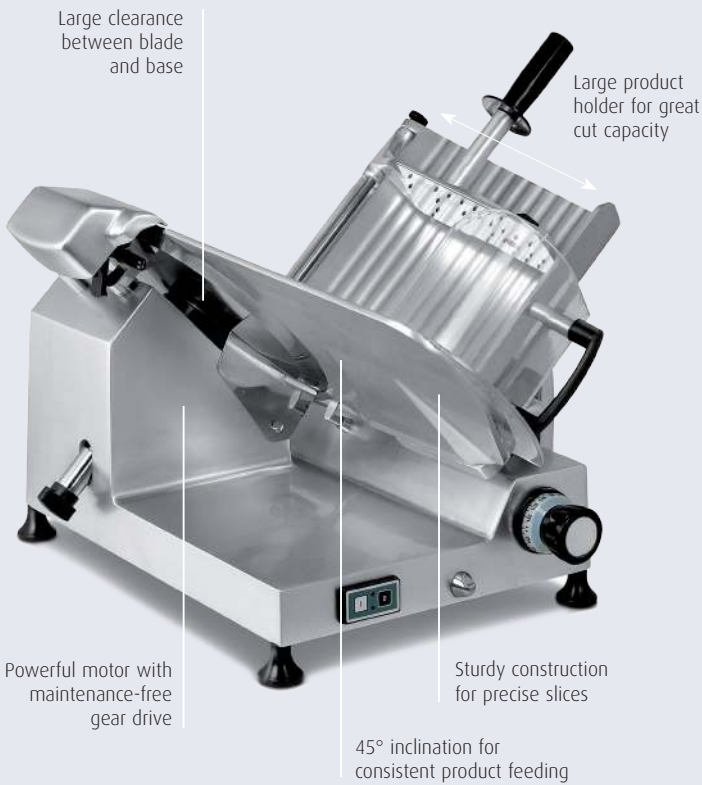

**AVAILABLE CONFIGURATIONS**

**ANODYZED**



All external aluminium parts are silver anodized:  
*TRADITIONAL SILVER FINISHING.*

**BASIC QUANTANIUM**



Gauge plate, blade and blade cover disc are non-stick coated. Remaining aluminium parts are anodized. Cheese and fresh meat cutting are eased up by Quantanium non stick coating.

**STANDARD OUTFIT**



User Manual, CE compliance declaration and "TEN BASIC RULES" Cardboard.



FAST CLEANER detergent, Cleaning nylon brush, Oiler.



Quantanium® with Titanium particles reinforced three-layer-non-stick coating will allow:  
● smoothness: difficult products

like cheese or fresh meat do not stick and products slide smoothly and frictionless;  
● higher resistance to abrasion;  
● resistance to most aggressive detergents.

**AVAILABLE OPTIONS**



**SBR** (Safe Blade Removal): It allows for quick and safe removal of the blade during slicer cleaning.



Non stick coated blade, perfect for cheese and fish cutting. Already included in Quantanium® configuration.



Serrated blade for frozen food cutting.



Stainless steel chute for vegetable cutting.



Inclined product holder. Easy to assemble, no tools needed.

**DIMENSIONS**

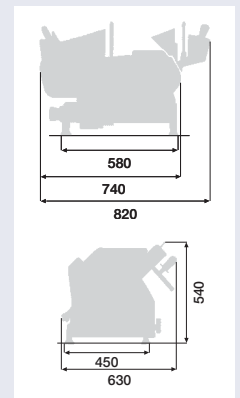

**SPECIFICATIONS AND SHIPPING INFORMATION**

Model name	Blade mm	Power Hp/kW	Drive	Cut Capacity mm	Cut thick. mm	Net weight kg
<b>SUPER START 350</b>	350	0,55/0,40	GEAR	260x190 250	15	48

**SHIPPING**

Dimension	Weight
cm 83x73x71	53 kg

All voltages and frequencies are available on request.

**SUPER START AUTO 300 SBR**

**DESCRIPTION**

SUPER START AUTO 300 SBR is a powerful automatic slicer that can also be used manually. Sturdy and high performing: carriage speed selection from 0 up to 60 slices/min. Easy to use, easy to clean. Ideal for supermarkets, restaurants, catering companies, laboratories. Gear drive guarantees maximum power when cheese, frozen or hard products are sliced. Frozen food package available: see optionals.

**FEATURES**

Anodized aluminium casting construction.  
 High quality hardened chromium steel alloy blade.  
 Powerful and noiseless continuous use motor.  
 Gear drive: long life, no maintenance (pict. 1).  
 Special product holder with adjustable fence and three-position heavy food pusher.  
 Large clearance between the back of the blade and the base provides access for easy cleaning (pict. 2).  
 Slice thickness precision adjustment: gasket-sealed mechanism (pict. 3).  
 Drip deflecting edge of the gauge plate: adjustment mechanism is protected.  
 No-drip edge base: easy cleaning (pict. 4).  
 Stainless steel ball-bearing blade pulley and special moisture-proof gasket.  
 Equipped with **SBR** (Safe Blade Removal) (pict. 5).  
 Built-in sharpener, removable for cleaning purposes: simple and convenient.  
 30° carriage angle: good visibility of the slice exit area and better ergonomics.

International homologations   



**AUTOMATIC GRAVITY SLICER**  
GEAR DRIVEN

Model  
**SUPER START AUTO 300 SBR**

Large clearance between blade and base.  
High protection against moisture

Powerful motor with maintenance-free gear drive

Adjustable fence and three-position heavy food pusher

Sturdy construction for precise slices

Wide slice exit area with no-drip profile

Thickness adjustment: gasket-sealed mechanism



**AVAILABLE CONFIGURATIONS**

**ANODYZED**



All external aluminium parts are silver anodized: *TRADITIONAL SILVER FINISHING.*

**BASIC QUANTANIUM**



Gauge plate, blade and blade cover disc are non-stick coated. Remaining aluminium parts are anodized: *CHEESE CUTTING IS NO MORE A PROBLEM.*

**TOTAL QUANTANIUM**



All external aluminium parts are black Quantanium non-stick coated to be resistant to all detergents: *THE BLACK APPEAL.*

**STANDARD OUTFIT**



**SBR** Safe Blade Removal

**AVAILABLE OPTIONS**



Non stick coated blade, perfect for cheese and fish cutting. Already included in **Quantanium®** configuration.



**Quantanium®** with Titanium particles reinforced three-layer non-stick coating will allow:  
● smoothness: difficult products

like cheese or fresh meat do not stick and products slide smoothly and frictionless;

- higher resistance to abrasion;
- resistance to most aggressive detergents.



User Manual, CE compliance declaration and "TEN BASIC RULES" Cardboard.



**FAST CLEANER** detergent, Cleaning nylon brush, Oiler.



Stainless steel chute for vegetable cutting.

**FROZEN FOOD PACKAGE**



Special product holder for frozen food



Serrated blade

**DIMENSIONS**

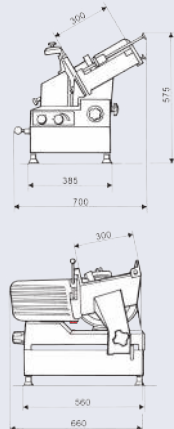

**SPECIFICATIONS AND SHIPPING INFORMATION**

Model name	Blade mm	Power Hp/kW	Drive	Cut Capacity mm	Cut thick. mm	Net weight kg
<b>SUPER START AUTO 300 SBR</b>	300	0,48/0,37	Gear	285x165  190	20	43

**SHIPPING**

Dimension	Weight
cm 83 x 73 x 71	50 kg

All voltages and frequencies are available on request.

**DESCRIPTION**

SUPER START AUTO 350 SBR is a 45° automatic gravity slicer.

Solid and overdimensioned unit that guarantees top performances in its category.

Gear drive guarantees maximum power when cheese, frozen or hard products are sliced.

Frozen food package available: see optionals.

Programmable slice counter available: see optionals.

Ideal for high volume work load in super and hypermarkets and for products size up to 250mm diameter.



**FEATURES**

Anodized aluminium casting construction: sturdy and light weight.

Stainless steel support frame.

High quality 350mm hardened chromium steel alloy blade.

Powerful and noiseless motor.

Gear drive: long life, no maintenance.

Variable carriage stroke according to product size guarantees maximum productivity.

Special product holder with adjustable fence and three-position heavy food pusher (pict. 1).

Equipped with **SBR** (Safe Blade Removal) (pict. 2, 3).

Generously sized for top performances and easy cleaning.

Elegant design for a slicer that can't pass unnoticed.

Built-in sharpener (pict. 4).



**AUTOMATIC GRAVITY SLICER**  
GEAR DRIVEN

Model  
**SUPER START AUTO 350 SBR**



**AVAILABLE CONFIGURATIONS**

**ANODYZED**



All external aluminium parts are silver anodized:  
*TRADITIONAL SILVER FINISHING.*

**BASIC QUANTANIUM**



Gauge plate, blade and blade cover disc are non-stick coated. Remaining aluminium parts are anodized. Cheese and fresh meat cutting are eased up by Quantanium non stick coating.

**STANDARD OUTFIT**



**SBR** Safe Blade Removal



User Manual, CE compliance declaration and "TEN BASIC RULES" Cardboard.



FAST CLEANER detergent, Cleaning nylon brush, Oiler.

**AVAILABLE OPTIONS**



Non stick coated blade, perfect for cheese and fish cutting. Already included in

Quantanium® configuration.



Stainless steel chute for vegetable cutting.



Programmable slice counter.



Quantanium® with Titanium particles reinforced three-layer non-stick coating will allow:  
● smoothness: difficult

products like cheese or fresh meat do not stick and products slide smoothly and frictionless;  
● higher resistance to abrasion;  
● resistance to most aggressive detergents.

**FROZEN FOOD PACKAGE**



Special product holder for frozen food.



Serrated blade.

**DIMENSIONS**

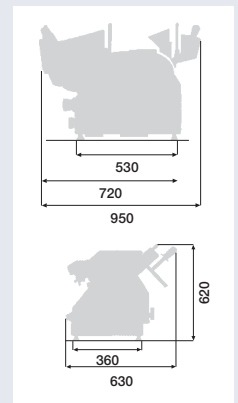

**SPECIFICATIONS AND SHIPPING INFORMATION**

Model name	Blade mm	Power Hp/kW	Drive	Cut Capacity mm	Cut thick. mm	Net weight kg
<b>SUPER START AUTO 350 SBR</b>	350	0,73/0,53	GEAR	260x190 250	15	62

**SHIPPING**

Dimension	Weight
cm 83x73x71	70 kg

All voltages and frequencies are available on request.

MONDIAL  
EVO  
SLICER

BELT  
DRIVEN  
SLICERS

GEAR  
DRIVEN  
SLICERS

MACHINES  
FOR MEAT  
PROCESSING

CLEAR  
SLICE EXIT  
SLICERS

COMPANY  
PROFILE



**Clear slice exit:** the entire area behind the blade is completely clear. This feature guarantees easy slice exit and the operator has a very wide slice collection area. These are belt driven slicers.

**A brilliant idea:** the motor is located below the blade, the drive system occupies minimum space; the machine body guarantees the necessary sturdiness.

**A practical solution:** no obstacles at the slice exit; slice collection area is wide and comfortable

**Unique design:** Mondial, Beta and Prima are unique slicers with a modern and attractive style.

BETA BN 300/350 SBR

BETA BS 300/350 SBR

PRIMA 250/300  
GREEN

GRAY

MONDIAL  
300/350 SBR

BLUE

RED

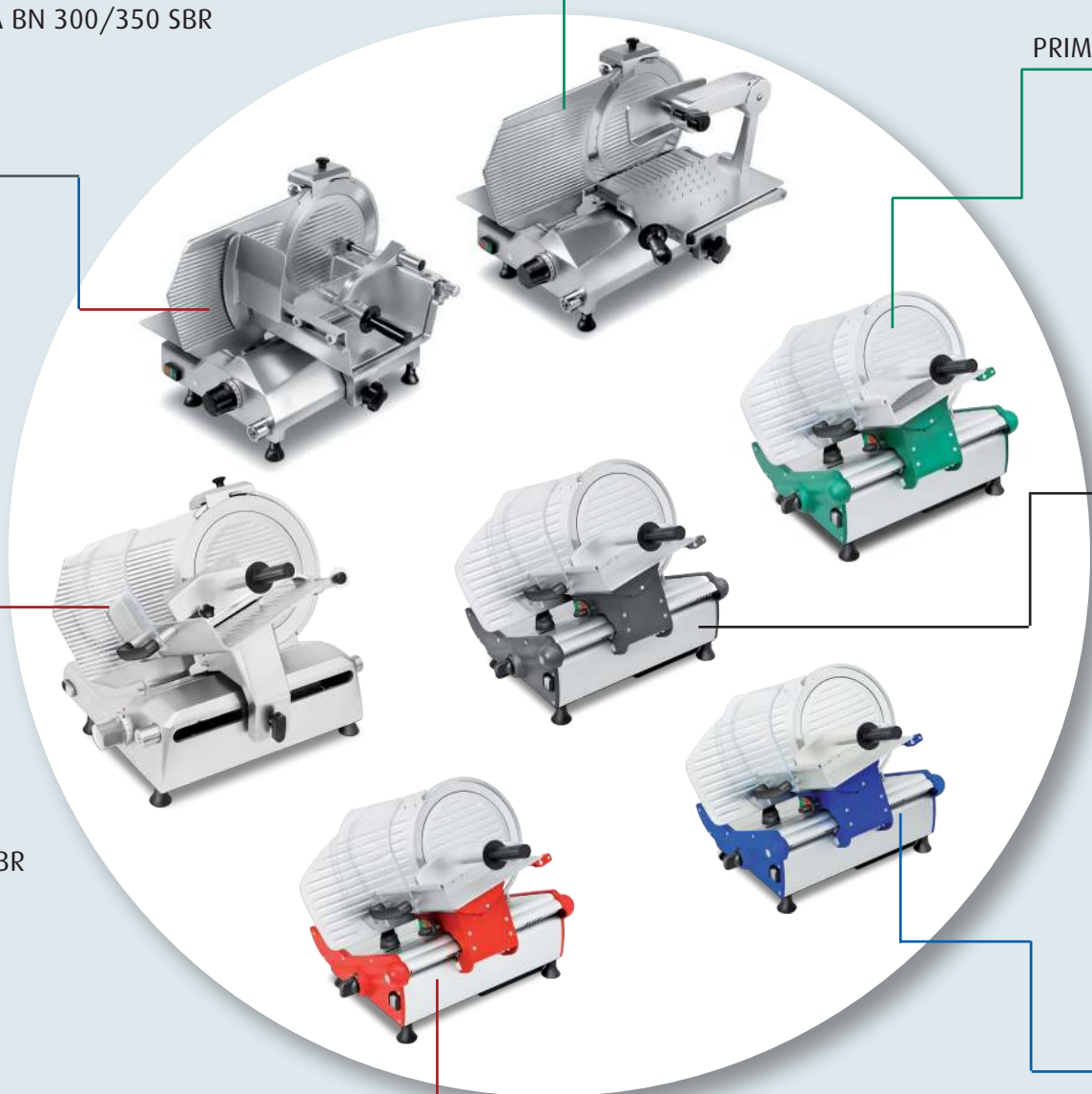

#### DESCRIPTION

PRIMA is a modern slicer with an unique and ergonomic design: multipurpose machine, ideal in the sandwich preparation and to slice different products. Fresh colours and nice design for easy installation in trendy bars. Ideal for coffee shops and small restaurants: not suited for supermarkets and big restaurants.

#### CLEAR SLICE EXIT DESIGN

The entire area behind the blade is completely free:

- no obstacles at the slice exit (pict.1),
- wide slice collection area (pict.2),
- attractive style.

#### FEATURES

Two available sizes: with 250 mm or 300 mm blade.  
Anodized extruded aluminium body with complementary parts in food-safe nylon.  
High quality hardened chromium steel alloy blade.  
Powerful and noiseless motor.  
Insulated electric controls with safety **No Volt Release**.  
Multygrip belt drive: always the right grip.  
Carriage smooth glide motion.  
Slice thickness precision adjustment: gasket-sealed mechanism.  
Stainless steel ball-bearing blade pulley.  
Four colours choice.  
Easy cleaning; removable product holder (pict. 3).  
Safe cleaning (pict. 4).  
Dedicated version for bread cutting (pict. 2).  
Dedicated version for fish cutting (pict.5).



MANUAL GRAVITY SLICER  
BELT DRIVEN/CLEAR SLICE EXIT

Model  
**PRIMA 250/300**

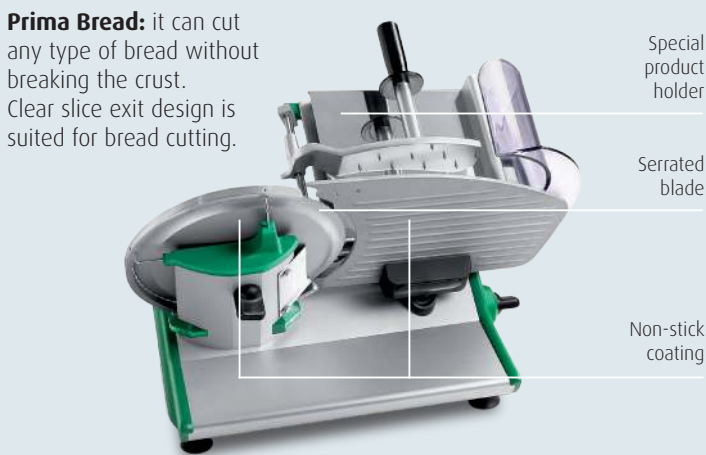

AVAILABLE CONFIGURATIONS

ANODYZED

QUANTANIUM

RED		
BLUE		
GRAY		
GREEN		



QuanTanium® with Titanium particles reinforced three-layer-non-stick coating will allow:

- smoothness: difficult

products like cheese or fresh meat do not stick and products slide smoothly and frictionless;

- higher resistance to abrasion;
- resistance to most aggressive detergents.

STANDARD OUTFIT



User Manual, CE compliance declaration and "TEN BASIC RULES" Cardboard.



FAST CLEANER detergent, Cleaning nylon brush, Oiler.

OPTIONALS



Special feet for galley fitting.

DIMENSIONS

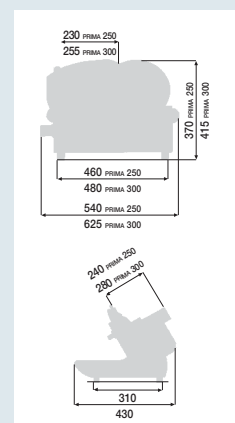

SPECIFICATIONS AND SHIPPING INFORMATION

Model name	Blade mm	Power Hp/kW	Drive	Cut Capacity mm	Cut thick. mm	Net weight kg
<b>PRIMA 250</b>	250	0,25/0,18	BELT	215x145 ○ 175	15	23
<b>PRIMA 300</b>	300	0,30/0,22	BELT	245x175 ○ 200	15	25

All voltages and frequencies are available on request.

SHIPPING

Dimension	Weight
cm 62x55x45	25 kg
cm 74x60x56	29 kg

### DESCRIPTION

MONDIAL is a gravity slicer with clear slice exit design. Well known and appreciated all over the world for its unique and unbeatable design, this slicer offers larger cut capacity, exact thickness regulation and smooth carriage stroke. Ideal machine for delicatessen, supermarkets and large size kitchens.

### CLEAR SLICE EXIT DESIGN

The entire area behind the blade is completely free:

- no obstacles at the slice exit,
- wide slice collection area (pict.2),
- attractive style.

### FEATURES

Two available sizes: with 300 mm or 350 mm blade.  
Anodized aluminium casting construction: sturdy and light weight.  
High quality hardened chromium steel alloy blade.  
Powerful and noiseless motor.  
Insulated electric controls with safety **No Volt Release**.  
Multygrip belt drive: always the right grip.  
Carriage smooth glide motion.  
Stainless steel ball-bearing blade pulley.  
Stainless steel food pusher toothed plate, removable for cleaning purposes (pict.1).  
Equipped with **SBR** (Safe Blade Removal) (pict.3).  
Built-in sharpener, removable for cleaning purposes (pict. 4).  
No-drip edge base: easy cleaning (pict. 5).  
International homologations **CE** **ETL** **NSF**



**MANUAL GRAVITY SLICER**  
BELT DRIVEN/CLEAR SLICE EXIT

Model  
**MONDIAL 300/350 SBR**

High protection against internal component moisture 

Large cut capacity



Clear slice exit and wide sliced product storage area

Sturdy construction for precise slices

**AVAILABLE CONFIGURATIONS**

**ANODYZED**



All external aluminium parts are silver anodized: *TRADITIONAL SILVER FINISHING.*

**BASIC QUANTANIUM**



Gauge plate, blade and blade cover disc are non-stick coated. Remaining aluminium parts are anodized: *CHEESE CUTTING IS NO MORE A PROBLEM.*

**STANDARD OUTFIT**



**SBR** Safe Blade Removal



User Manual, CE compliance declaration and "TEN BASIC RULES" Cardboard.



**FAST CLEANER** detergent, Cleaning nylon brush, Oiler.

**AVAILABLE OPTIONALS**



Non stick coated blade, perfect for cheese and fish cutting. Already included in **Quantanium®** configuration.



Serrated blade for frozen food cutting.



Serrated and non stick coated blade for bread cutting.



**Quantanium®** with Titanium particles reinforced three-layer non-stick coating will allow:

- smoothness: difficult products

like cheese or fresh meat do not stick and products slide smoothly and frictionless;

- higher resistance to abrasion;
- resistance to most aggressive detergents.



Stainless steel chute for vegetable cutting.



**ES** (Energy saver): drastically reduces power consumption.







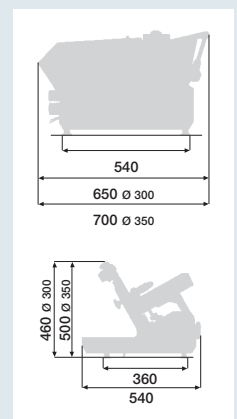



Inclined product holder. Easy to assemble, no tools needed.

**DIMENSIONS**



**SPECIFICATIONS AND SHIPPING INFORMATION**

		<b>HP</b>				
Model name	Blade mm	Power Hp/kW	Drive	Cut Capacity mm	Cut thick. mm	Net weight kg
<b>MONDIAL 300 SBR</b>	300	0,35/0,25	BELT	 290x140  200	30	30
<b>MONDIAL 350 SBR</b>	350	0,35/0,25	BELT	 290x190  225	30	33

All voltages and frequencies are available on request.

**SHIPPING**

Dimension	Weight
cm 79x64x58	37 kg
cm 79x64x58	41 kg

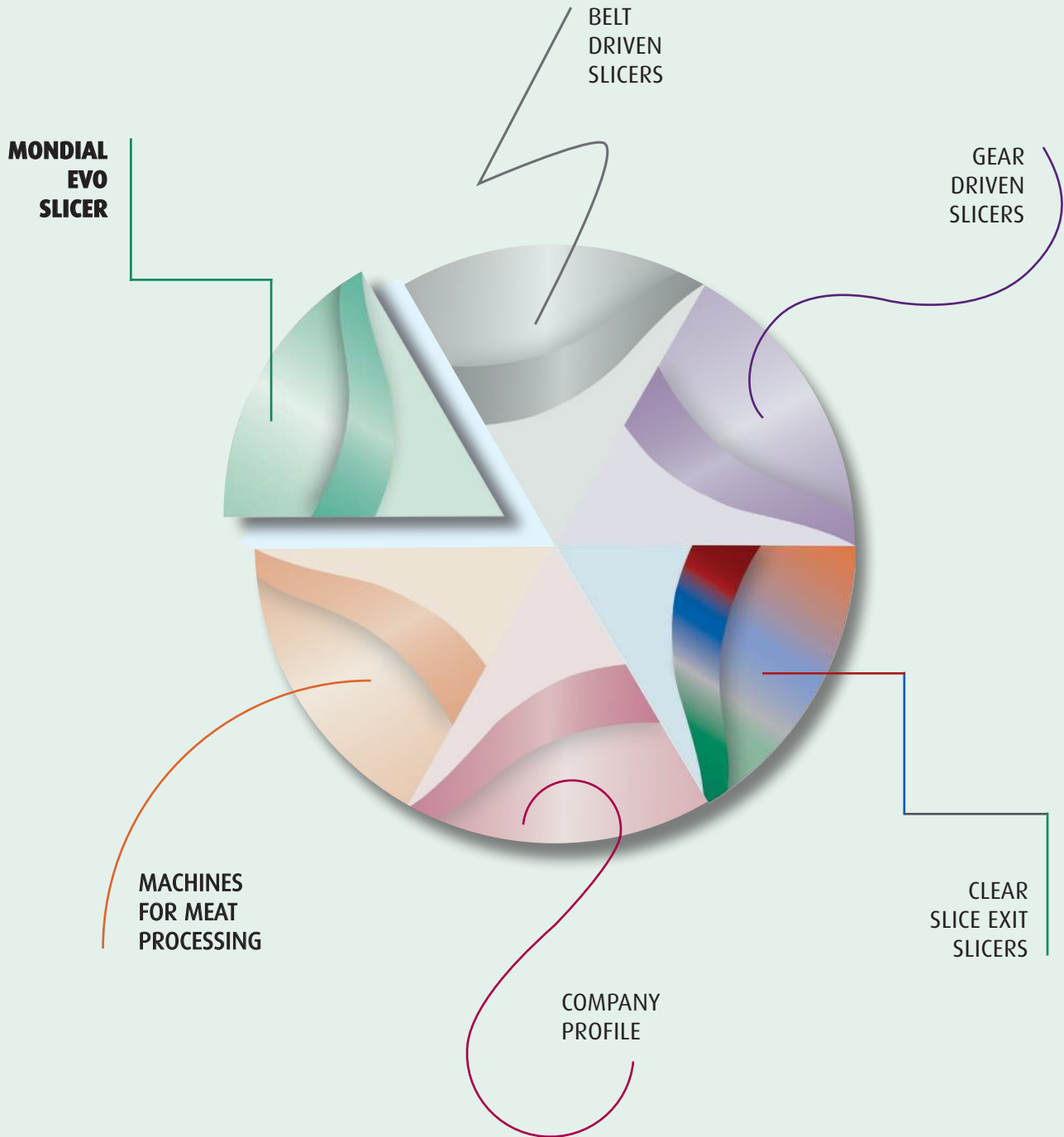

**Clear Slice Exit + SBR (Safe Blade Removal) + Quantanium + Energy Saver =**



**Mondial Evo**



# MONDIAL EVO

Today is playing its four aces

**CSE** Clear Slice Exit

**SBR** Safe Blade Removal

**QTQ** **Quantanium** 

**ES**  **ENERGYSAVER**



**CSE** Clear Slice Exit

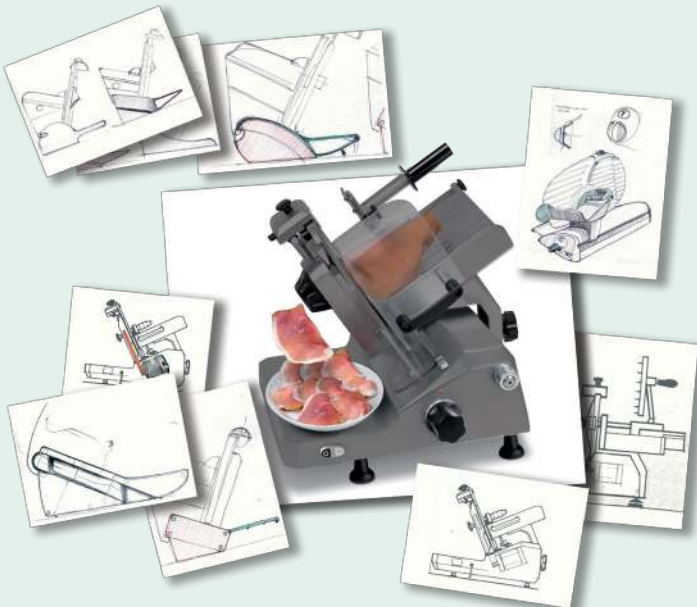

Our designers styled the first Mondial combining genius and convenience: the result was an innovative and balanced structure. The motor is located below the blade and transmission occupies a restricted area thus leaving the area behind the blade completely free: slice collection area is wider.

Since the blade inclination is at 30° (instead of 45°) you will be able to work in an upright position which is less tiring and offers a total control of the cutting process.

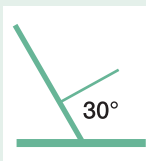

**MONDIAL EVO with CSE:**  
ergonomic-oriented design for your comfort

**SBR** Safe Blade Removal

Injuries with slicers generally do not occur during normal work but rather during cleaning operations. Difficult areas to clean on a slicer are those close to the blade: the blade-ring-guard, the blade bearing structure and the area behind the blade. We have studied the most effective solution: by removing the blade in a rapid and safe way we eliminate any cutting risk and cleaning is possible where any cloth could dare to arrive. Our **SBR** is since years the invention that has made thousand of chefs, grocers and butchers happy to work with. See how to remove the blade with four simple moves. **SBR** can help you to easily slice frozen products (for example to

prepare a carpaccio or a Chinese hot pot). Ask for an additional serrated blade that will allow you a rapid replacement. Finally **SBR** is adopted by supermarkets where at half day



re-sharpen of the blade is required, but time is a problem: a swift PIT-STOP to remove the blade and fit the well sharpened one (to be ordered separately).

**MONDIAL EVO with SBR:**  
safety and hygiene without barriers



**MONDIAL EVO: A CLASSIC IS RENEWED**

35 thousand **MONDIAL** have been produced and sold all over the world since 1968. Thanks to the brilliant initial intuitions and the subsequent continuous updating

**MONDIAL** still is nowadays a sales leader.



**QT:** 

**QuanTanium®** with Titanium particles reinforced three-layer non-stick coating will allow:

- smoothness: difficult products like cheese or fresh meat do not stick and products slide smoothly and frictionless ;
- higher resistance to abrasion;
- resistance to most aggressive detergents.

Cut requires a lot less effort, it's

more accurate and cleaning is very rapid; furthermore your **MONDIAL EVO** will remain as new for many years without undergoing the typical deterioration of the anodised aluminium. See a comparison among the performances of the most commonly used materials for professional slicers:

Assessment from 1 to 10	ABRASION RESISTANCE	FLOWABILITY	RESISTANCE TO DETERGENTS	TOTAL
<b>QuanTanium®</b>	8	10	8	26
ANODIZED ALUMINIUM	6	8	6	20
STAINLESS STEEL	10	6	10	26

**QuanTanium® offers superior performances as to traditional anodized aluminium and competes with stainless steel.**

**ANSWERS TO FREQUENTLY ASKED QUESTIONS**

- Q:** Can **QuanTanium®** coated surfaces have negative effects on food ? **A:** No, because **QuanTanium®** is inert and it does not have any effect on food condition or taste.
- Q:** Is **QuanTanium®** dangerous for your health? **A:** No, because it has been made from inert, nontoxic materials.
- Q:** How can it be guaranteed that **QuanTanium®** is a suitable and lasting coating? **A:** The **QuanTanium®** coated **Rheninghaus** slicer has obtained the **NSF Certification**.

**MONDIAL EVO with QT:**  
who tries it will never want something different.

**ES**  **ENERGYSAVER**

**ES** is an electronic device that reduces the average electric consumption thus contributing in reducing the environmental impact. With **ES** the motor supplies its maximum power during the cutting phase only; energy consumption during the other phases is reduced. The blade keeps rotating always at the same speed and the pilot light changing colour is informing you

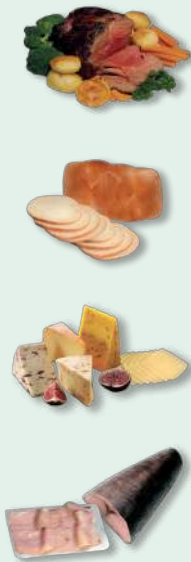

if your slicer is working in **"ECONOMY"** or in **"POWER"** mode. **ES** turns OFF your slicer after 5 minutes idleness, in case you forgot it ON. Tests have proved that **ES** determines an average energy saving of 40%. **ES** is housed inside the watertight control box and it has no need of maintenance. **ES** determines a reduction in motor heating thus improving its efficiency.



**MONDIAL EVO with ES:**  
your contribution in reducing environmental impact.



# MONDIAL EVO

## SPECIAL FEATURES

Non-stick **Quantanium®** coating

High protection against internal component moisture



Clear slice exit and wide sliced product storage area

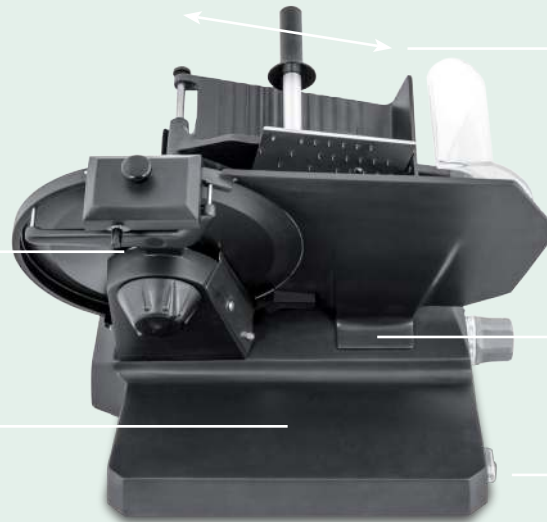

Large cut capacity

Sturdy construction for precise slices

Electric controls with **Energy Saver**

## STANDARD OUTFIT



**SBR** Safe Blade Removal



User Manual, CE compliance declaration and "TEN BASIC RULES" Cardboard



**FAST CLEANER** detergent  
Cleaning nylon brush  
Oiler

## OPTIONALS

You may enhance your **MONDIAL EVO** by choosing among these exclusive optionals.



Serrated blade for frozen products



Special blade for bread



Additional standard **Quantanium®** coated blade



Stainless steel vegetable cutting chute



Inclined product-holder for fish cutting

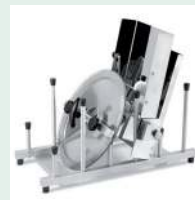

Accessories storage rack

## DIMENSIONS

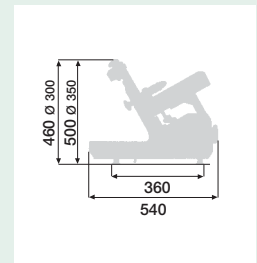
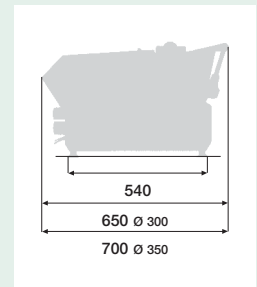

## SPECIFICATIONS AND SHIPPING INFORMATION

Model name	Blade mm	Power Hp/kW	Drive	Cut Capacity mm	Cut thick. mm	Net weight kg
<b>Mondial EVO 300 SBR</b>	300	0,35/0,25	Belt	290x140  210	30	30
<b>Mondial EVO 350 SBR</b>	350	0,35/0,25	Belt	285x190  250	30	34

All voltages and frequencies are available on request.

## SHIPPING

Dimension	Weight
cm 79x64x58	37 kg
cm 79x64x58	41 kg

### DESCRIPTION

BETA BN is a vertical meat slicer with clear slice exit design. It is possible to cut slices of thickness up to 30 mm. Thin carpaccio or thick steaks become an easy job with Beta. Easy and safe cleaning after 10 hours of hard work. Ideal machine for butcher shops, supermarkets and large size kitchens.

### CLEAR SLICE EXIT DESIGN

The entire area behind the blade is completely free:

- no obstacles at the slice exit,
- wide slice collection area,
- attractive style.

### FEATURES

Two available sizes: with 300 mm or 350 mm blade.  
Anodized aluminium casting construction: sturdy and light weight.  
High quality hardened chromium steel alloy blade.  
Powerful and noiseless motor.  
Insulated electric controls with safety **No Volt Release**.  
Multygrip belt drive: always the right grip.  
Carriage smooth glide motion.  
Stainless steel ball-bearing blade pulley.  
Equipped with **SBR** (Safe Blade Removal) (pict. **1**, **2**).  
Wide receiving stainless steel tray, removable for cleaning purposes (pict. **3**).  
Built-in sharpener, removable for cleaning purposes (pict. **4**).



**MANUAL VERTICAL SLICER**  
BELT DRIVEN/CLEAR SLICE EXIT

Model  
**BETA BN 300/350 SBR**

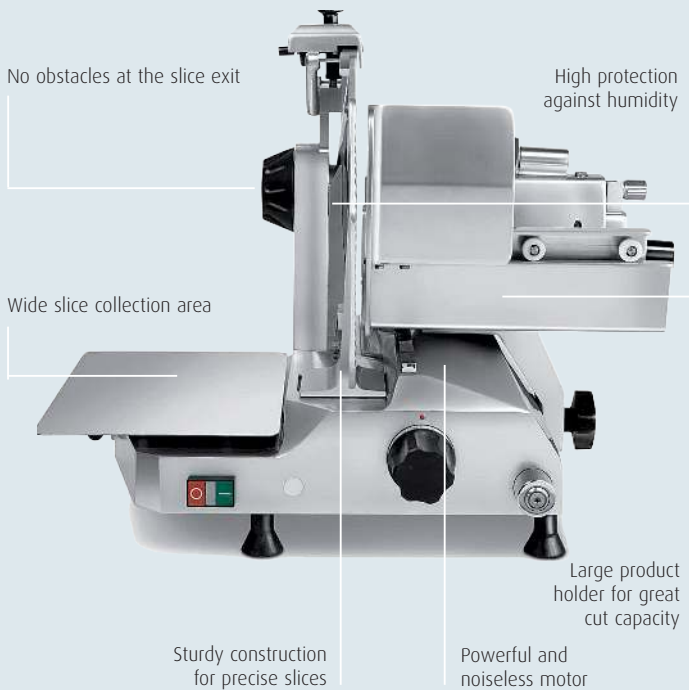

**AVAILABLE CONFIGURATIONS**

**ANODYZED**



All external aluminium parts are silver anodized: *TRADITIONAL SILVER FINISHING.*

**BASIC QUANTANIUM**



Gauge plate, blade and blade cover disc are non-stick coated. Remaining aluminium parts are anodized: *CHEESE CUTTING IS NO MORE A PROBLEM.*

**STANDARD OUTFIT**



**SBR** Safe Blade Removal

**AVAILABLE OPTIONS**



Non stick coated blade, perfect for cheese and fish cutting. Already included in **Quantanium®** configuration.



**Quantanium®** with Titanium particles reinforced three-layer-non-stick coating will allow:  
● smoothness: difficult products

like cheese or fresh meat do not stick and products slide smoothly and frictionless;  
● higher resistance to abrasion;  
● resistance to most aggressive detergents.



User Manual, CE compliance declaration and "TEN BASIC RULES" Cardboard.

**ES** (Energy saver): drastically reduces power consumption.



**FAST CLEANER** detergent, Cleaning nylon brush, Oiler.



Serrated blade for frozen food cutting.

**DIMENSIONS**

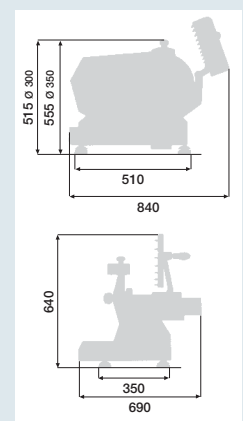

**SPECIFICATIONS AND SHIPPING INFORMATION**

Model name	Blade mm	Power Hp/kW	Drive	Cut Capacity mm	Cut thick. mm	Net weight kg
<b>BETA BN 300 SBR</b>	300	0,35/0,25	BELT	270x205 ○ 205	30	35
<b>BETA BN 350 SBR</b>	350	0,35/0,25	BELT	270x230 ○ 230	30	36

**SHIPPING**

Dimension	Weight
cm 83x73x71	43 kg
cm 83x73x71	44 kg

All voltages and frequencies are available on request.

**DESCRIPTION**

BETA BS is a vertical slicer with clear slice exit design. It is the most suited slicer for thin cutting of prosciutto, Italian hams, cold-cuts and processed meat. Ideal machine for delicatessen, supermarkets and large size kitchens.

**CLEAR SLICE EXIT DESIGN**

The entire area behind the blade is completely free:

- no obstacles at the slice exit,
- wide slice collection area,
- attractive style.

**FEATURES**

Two available sizes: with 300 mm or 350 mm blade.  
Anodized aluminium casting construction: sturdy and light weight.  
High quality hardened chromium steel alloy blade.  
Powerful and noiseless motor.  
Insulated electric controls with safety **No Volt Release**.  
Multygrip belt drive: always the right grip.  
Carriage smooth glide motion.  
Stainless steel ball-bearing blade pulley.  
The clutch coupled food-pusher arm guarantees a stable hold of the product to be sliced (pict. 1, 2).  
Equipped with **SBR** (Safe Blade Removal) (pict. 3).  
Wide receiving stainless steel tray, removable for cleaning purposes. Built-in sharpener, removable for cleaning purposes (pict. 4).



**DIMENSIONS**

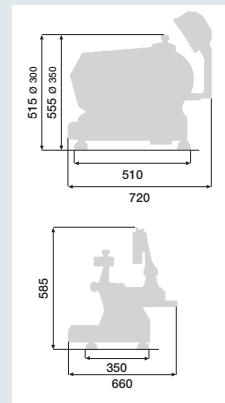

**STANDARD OUTFIT**



**SBR**  
Safe  
Blade  
Removal



User Manual, CE compliance declaration and "TEN BASIC RULES" Cardboard.



**FAST CLEANER** detergent, Cleaning nylon brush, Oiler.

**AVAILABLE OPTIONS**



Non stick coated blade, perfect for cheese and fish cutting. Already included in **Quantanium®** configuration.



Serrated blade for frozen food cutting.



**ES** (Energy saver): drastically reduces power consumption.

**SPECIFICATIONS AND SHIPPING INFORMATION**

Model name	Blade mm	Power Hp/kw	Drive	Cut Capacity mm	Cut thick. mm	Net weight kg
<b>BETA BS 300 SBR</b>	300	0,35/0,25	BELT	290x140 ○ 200	30	30
<b>BETA BS 350 SBR</b>	350	0,35/0,25	BELT	290x190 ○ 225	30	33

**SHIPPING**

Dimension	Weight
cm 83x73x71	37 kg
cm 83x73x71	41 kg

All voltages and frequencies are available on request.

BELT  
DRIVEN  
SLICERS



GEAR  
DRIVEN  
SLICERS

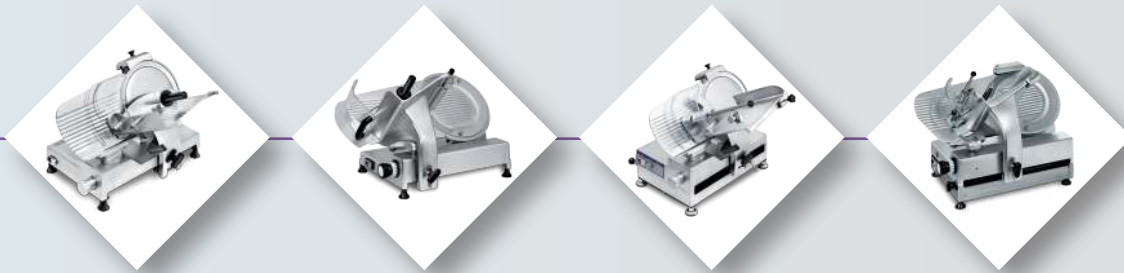

CLEAR  
SLICE EXIT  
SLICERS

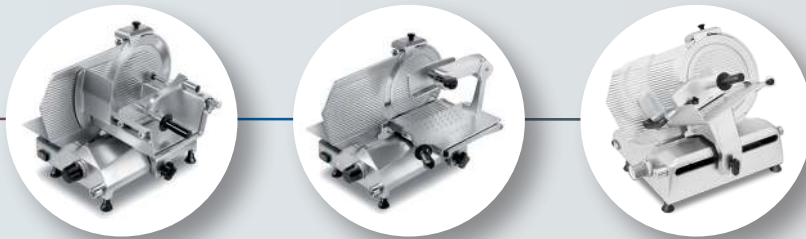
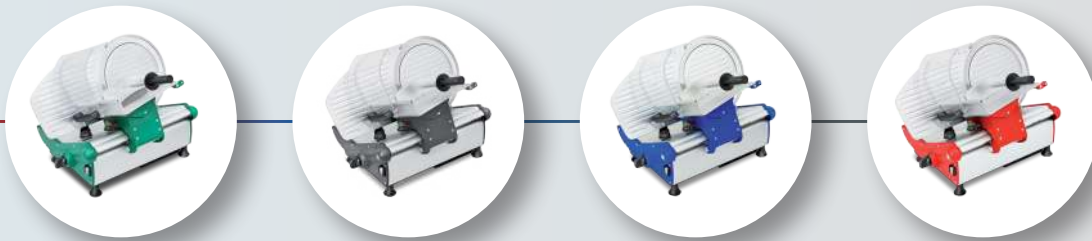

MONDIAL  
EVO  
SLICER



Our selection of useful optionals, created to simplify the work and to stimulate creativity. Our worldwide experience is at your disposal to suggest innovative solutions.

**SBR** (Safe Blade Removal) allows for quick and safe removal of the blade in 4 steps.

Useful for:

- Daily cleaning of the blade, the blade ring-guard and the area behind the blade;
- Rapid replacement of special blades such as the non-stick coated blade and the serrated blade for frozen food.
- Rapid replacement of the exhausted blade with a well sharpened one for a non-stop cycle of the slicer.

Herebelow you will find our selection of special blades: thanks to the SBR system it is really easy and quick to interchange different blades for a more precise and professional use. Each additional blade is supplied in our special vacuum packaging.

## SBR



The **Quantanium** non-stick coated **blade** is normally used to cut cheese but it offers great performances also when cutting fresh meat and any other type of products. It is not suggested for frozen products cutting.

The **serrated blade** for cutting of frozen products.

The serrated/non-stick coated **blade for** cutting of **bread**.

The **extra-chrome blade**, for extra-humid environments.

## SPECIAL BLADES

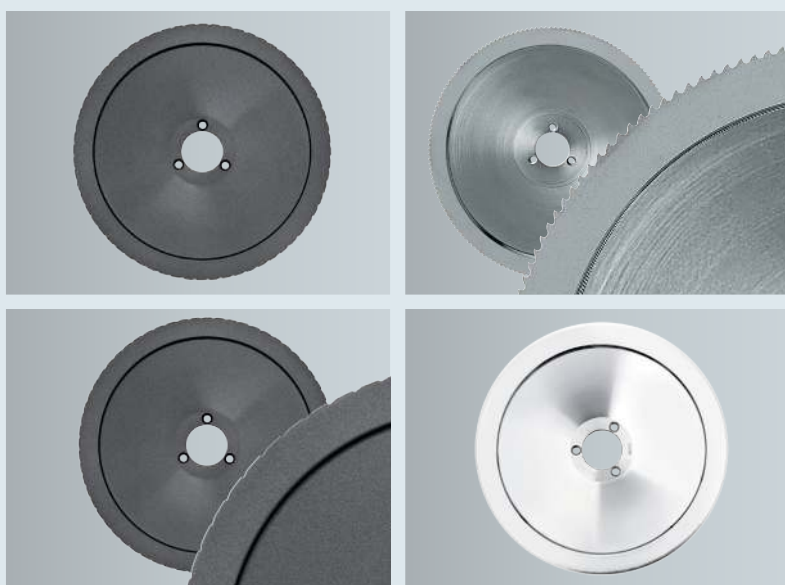

## OPTIONALS LIST

### SBR

- Safe Blade Removal system

### SPECIAL BLADES

- QuanTanium non-stick coated blade
- Serrated blade
- Blade for bread
- Extra-chrome blade

### PRODUCT HOLDERS

- Vegetable chute
- Inclined product holder
- Product holder for frozen food

- Accessories holding rack
- Frozen food package
- ES - Energy saver
- Special feet for ship fitting

And now, three special chutes/product holders that are to be matched to different types of products and of cuts:

The stainless steel **vegetable chute** for easy vegetable cutting: ideal to cut rapidly and with precision cabbage, salad, tomatoes, onions, etc. It is also well used for squids and octopus (pict.1).

**Inclined product holder:** the variable cutting angle is useful when width of slice needs to be increased. It is very much used to cut fish filets or salami oval slices (pict.2).

**Product holder for frozen food** with double arm food-pusher and adjustable fence: it is used when it is necessary to immobilize the product with maximum safety. It is very useful when cutting frozen products on automatic slicers (pict.3).

Blades and **accessories holding rack:** for tidy and safe storage of additional blades and accessories (pict.4).

## SPECIAL CHUTES/PRODUCT HOLDERS

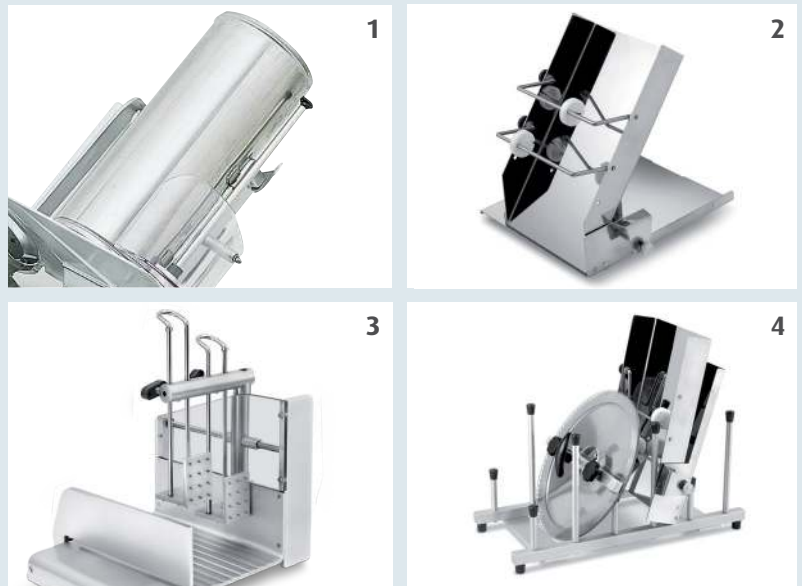

**FROZEN FOOD PACKAGE:** product-holder with double arm food pusher and adjustable fence + serrated blade. Our suggestion for easy cutting of frozen products (pict.1).

**ES (Energy Saver):** our/your contribution to environmental impact. This exclusive and unique device has proven capable of obtaining an average energy saving of 40%. Furthermore, for more saving and safety, it turns off the slicer after 5 minutes idleness, in case you forgot it ON. ES is maintenance free and it determines a reduction in motor heating thus improving its efficiency (pict.2).

**Special feet for ship fitting.** Aluminium studs to lock the slicer: required for galley equipment (pict.3).

**REFILL!** It is possible to order oiler refill, nylon brush and Fast Cleaner (single bottle or 5/10 liter refill tank) (pict.4).

## FROZEN FOOD PACKAGE



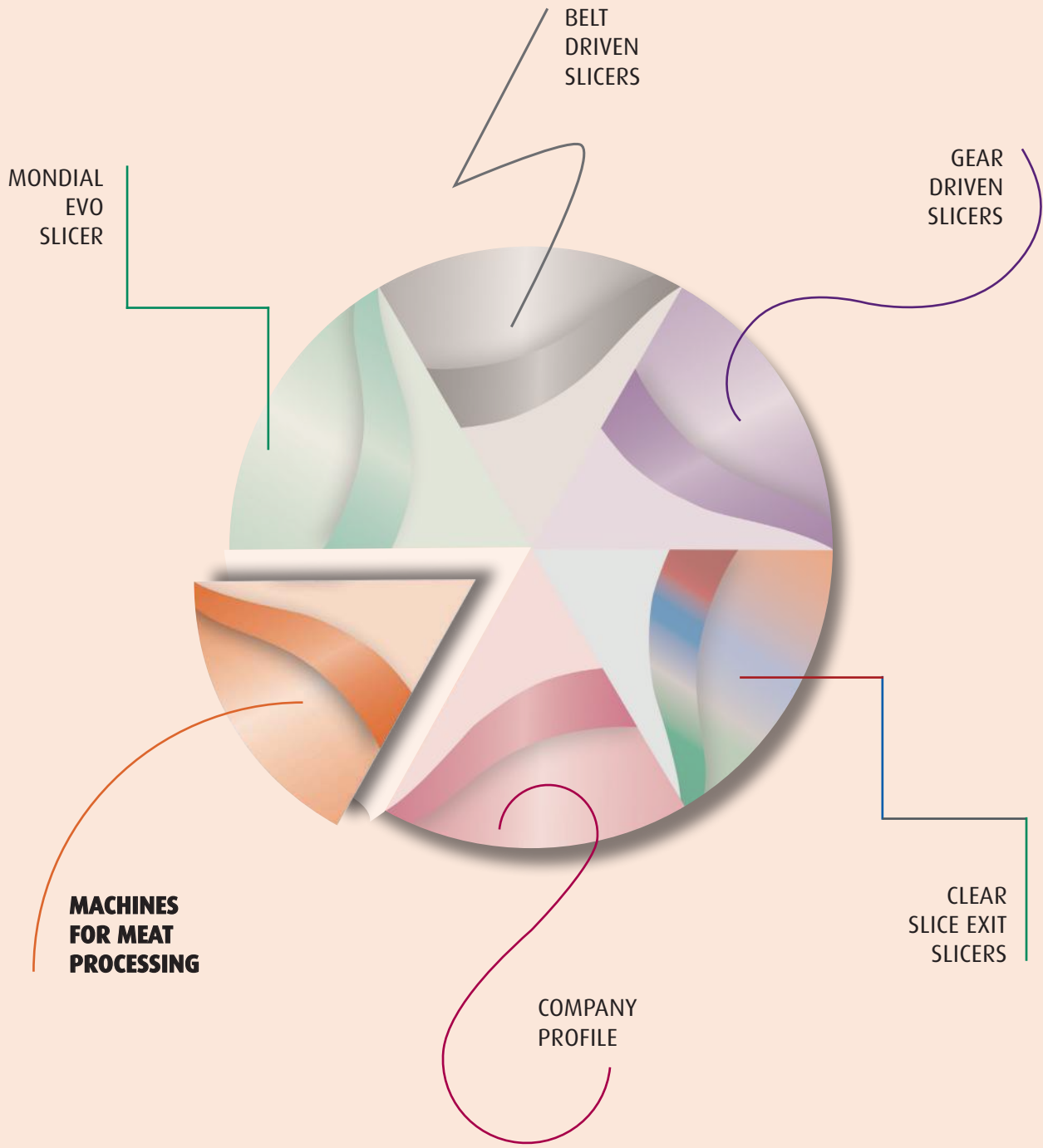

PRIMA GOURMET 5

PRIMA GOURMET 3

LABOR 32

VELOX SBR M  
VELOX SBR L

SATURNO 22

FAST 100/130



EVE/2000-12

EVE/ALL-12

EVE/2000-22

EVE/ALL-22

**VELOX SBR M • VELOX SBR L**

**DESCRIPTION**

VELOX is a bench band bone saw. Anodized aluminium casting body ensures blade linear rotation, without flexions. Ideal for butcheries, supermarkets, galley and large size kitchens.

**FEATURES**

Seamless anodized aluminium body.  
Stainless steel working surface and portioner.  
Automatic blade tensioner.  
Blade scraper and hard steel blade guide.  
SBR system allows to remove blade and pulleys without using tools for daily cleaning.

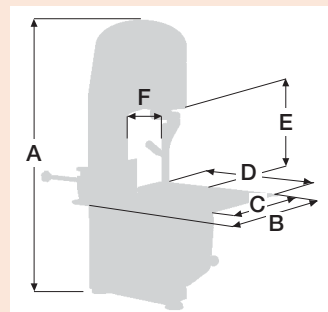

	VELOX SBR M	VELOX SBR L
A	800	930
B	650	780
C	400	500
D	440	500
E	215	245
F	195	235

**SPECIFICATIONS AND SHIPPING INFORMATION**

Model name	Blade mm	Power Hp/kW	Structure	Cut Capacity mm	Net weight kg
<b>VELOX SBR M</b>	1650	0,90/065	Anodized aluminium	190x220	38
<b>VELOX SBR L</b>	1980	0,90/0,65	Anodized aluminium	205x260	47

**SHIPPING**

Dimension	Weight
cm 69x106x62	44 kg
cm 69x106x62	56 kg

All voltages and frequencies are available on request.

**DESCRIPTION**

FAST is a manual hamburger press / patty machine. Easy to use for rapid production of hand made hamburgers. Long life is guaranteed by first quality materials. Ideal to prepare customised hamburgers in front of your customer. Use: butcheries, restaurants, laboratories.



**FEATURES**

Two available sizes: 100mm or 130mm diameter. Seamless anodized aluminium body. No maintenance mechanism. Food contact surfaces in stainless steel. Hamburger rapid extraction system. Easy to clean.

Model name	Net weight kg
<b>FAST 100</b>	5
<b>FAST 130</b>	6

SHIPPING	
Dimension	Weight
cm 24x22x29	6 kg
cm 24x22x29	7 kg

**DESCRIPTION**

EVE/ALL-12 and EVE/ALL-22 are reliable meat mincers able to process meat efficiently, safely and hygienically. Trustworthy and solid machines that won't let you down. Ideal for restaurants, nursery/schools, canteens.

**FEATURES**

- Sturdy anodized aluminium casting construction.
- Powerful continuous use motor.
- Noiseless and waterproof oil bath helical gear box.
- Top quality stainless steel plate and knife included.
- Mincing group available in Cast Iron or in Stainless Steel.
- Easy to remove mincing group.
- Stainless steel hopper and receiving tray.
- Easy cleaning.





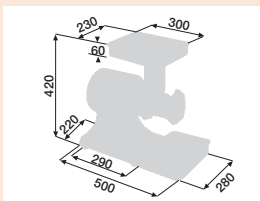
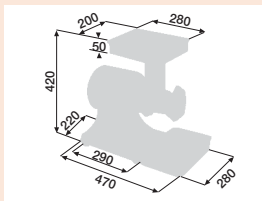

**EVE/ALL-12**

**EVE/ALL-22**



**SPECIFICATIONS AND SHIPPING INFORMATION**

					
Model name	Plate mm	Power Hp/kW	Structure	Output hour kg	Net weight kg
<b>EVE/ALL-12</b>	70	1,00/0,73	Aluminium casting	180	24
<b>EVE/ALL-22</b>	82	1,50/1,10	Aluminium casting	280	26

**SHIPPING**

Dimension	Weight
cm 50x29x47	27 kg
cm 50x29x50	29 kg

All voltages and frequencies are available on request.

**DESCRIPTION**

EVE/2000-12 and EVE/2000-22 are reliable meat mincers able to process meat efficiently, safely and hygienically. Trustworthy and solid machines that won't let you down. Ideal for restaurants, nursery/schools, canteens.

**FEATURES**

- Seamless stainless steel body.
- Powerful continuous use motor.
- Noiseless and waterproof oil bath gear box.
- Top quality stainless steel plate and knife included.
- Mincing group available in Cast Iron or in Stainless Steel.
- Easy to remove mincing group.
- Stainless steel hopper and receiving tray.
- Easy cleaning.





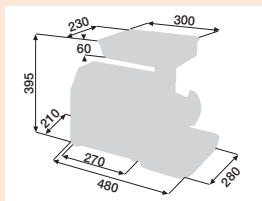
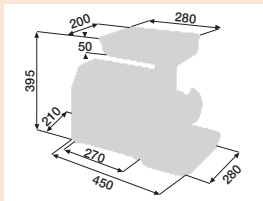

**EVE/2000-12**

**EVE/2000-22**



**SPECIFICATIONS AND SHIPPING INFORMATION**

					
Model name	Plate mm	Power Hp/kW	Structure	Output hour kg	Net weight kg
<b>EVE/2000-12</b>	70	1,00/0,73	Stainless steel	180	25
<b>EVE/2000-22</b>	82	1,50/1,10	Stainless steel	280	27

**SHIPPING**

Dimension	Weight
cm 50x29x47	28 kg
cm 50x29x50	30 kg

All voltages and frequencies are available on request.

**SATURNO 22 • LABOR 32**

**DESCRIPTION**

Saturno 22 and LABOR 32 are reliable meat mincers able to process massive volume of meat efficiently, safely and hygienically. Trustworthy and solid machines that won't let you down. Ideal for butcheries and supermarkets.

**FEATURES**

- Seamless stainless steel body.
- Powerful continuous use motor.
- Noiseless and waterproof oil bath helical gear box.
- Top quality stainless steel plate and knife included.
- Stainless steel mincing group.
- Easy to remove mincing group.
- Stainless steel hopper and receiving tray. Easy cleaning.

LABOR 32: thanks to 3 Hp motor is able to mince frozen meat too.

Detail of the stainless steel mincing group.





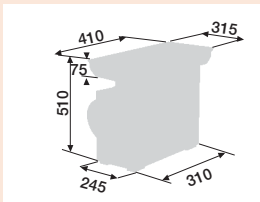
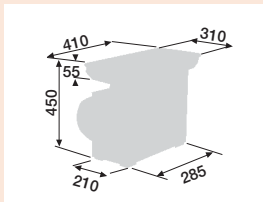

**SATURNO 22**

**LABOR 32**



**SPECIFICATIONS AND SHIPPING INFORMATION**

					
Model name	Plate mm	Power Hp/kw	Structure	Output hour kg	Net weight kg
<b>SATURNO 22</b>	82	1,60/1,17	Stainless steel	300	31
<b>LABOR 32</b>	100	3,00/2,20	Stainless steel	500	42

<b>SHIPPING</b>	
Dimension	Weight
cm 42x36x57	35 kg
cm 57x44x57	47 kg

All voltages and frequencies are available on request.



**DESCRIPTION**

PRIMA GOURMET is a food processor able to cut, mix, whip and knead. Ideal to process mayonnaise, paté, cream sauce, meat-balls, hamburgers, milk-shakes, homogenized food, toppings, dough. Use: restaurants, schools, canteens, deli shops.

**FEATURES**

Seamless anodized aluminium body.  
Stainless steel bowl and cutting group.  
Transparent lid.  
Safety switch stops blades rotation when lid is removed.  
Blades and bowl design guarantee perfect cut even with small quantity of food.

**DESCRIPTION**

Grater suitable to grate stale bread and wheatered cheese. Perfect with Italian parmesan-cheese. Use: restaurants, schools, canteens, deli shops.

**FEATURES**

Sturdy anodized aluminium casting construction  
Powerful continuous use motor.  
Stainless steel grater roll.  
Easy cleaning

**EVE**



**SPECIFICATIONS AND SHIPPING INFORMATION**

SPECIFICATIONS AND SHIPPING INFORMATION				SHIPPING	
	<b>HP</b>	<b>kg</b>	<b>cm</b>	Dimension	Weight
Model name	Power	Net weight kg	Overall dimensions	cm 50x40x39	13 kg
<b>PRIMA GOURMET 3</b>	0,50/036	11	280x370x290	cm 50x40x46	15 kg
<b>PRIMA GOURMET 5</b>	0,50/0,36	12	280x370x350	cm 46x38x48	22 kg
<b>EVE</b>	1,00/0,74	20	420x320x440		

All voltages and frequencies are available on request.

Model

**EVE/ALL-G12 · EVE/ALL-G22**  
**EVE/2000-G12 · EVE/2000-G22**

**DESCRIPTION**

Meat-mincer-Grater: multifunction machine available in 12 or 22 size.  
 It can process meat efficiently and grate cheese or bread.  
 Use: restaurants, schools, canteens.

**FEATURES**

- Two available sizes: 12 or 22.
- Two available configurations: aluminium casting or stainless steel.
- Powerful continuous use motor.
- Noiseless and waterproof oil bath gear box.
- Top quality stainless steel plate and knife included.
- Easy to remove mincing group.
- Stainless steel grater roll.
- Easy cleaning.





**EVE/ALL-G12 · EVE/ALL-G22**



**EVE/2000-G12 · EVE/2000-G22**



**SPECIFICATIONS AND SHIPPING INFORMATION**

				
Model name	Plate mm	Power Hp/kw	Hour/rate production kg	Net weight kg
<b>EVE/ALL-G12</b>	70	1,00/0,74	200	25
<b>EVE/ALL-G22</b>	82	1,50/1,10	300	31
<b>EVE/2000-G12</b>	70	1,00/0,74	200	27
<b>EVE/2000-G22</b>	82	1,50/1,10	300	37

<b>SHIPPING</b>	
Dimension	Weight
cm 62x31x48	27 kg
cm 68x33x51	33 kg
cm 56x31x39	29 kg
cm 62x31x45	39 kg

All voltages and frequencies are available on request.



International homologations



Quality assurance



Safety-approvals



Total hygiene



**Rheninghaus S.r.l.** Strada del Cascinotto, 139/39L - 10156 Torino - Italy

Tel. +39 011 223 75 14 - +39 011 220 14 02 - Fax +39 011 273 51 09 - [info@rheninghaus.com](mailto:info@rheninghaus.com) - [www.rheninghaus.com](http://www.rheninghaus.com)

