

Operating instructions

Freezer

Read the operating instructions before switching on for the first time

Page 6

GB

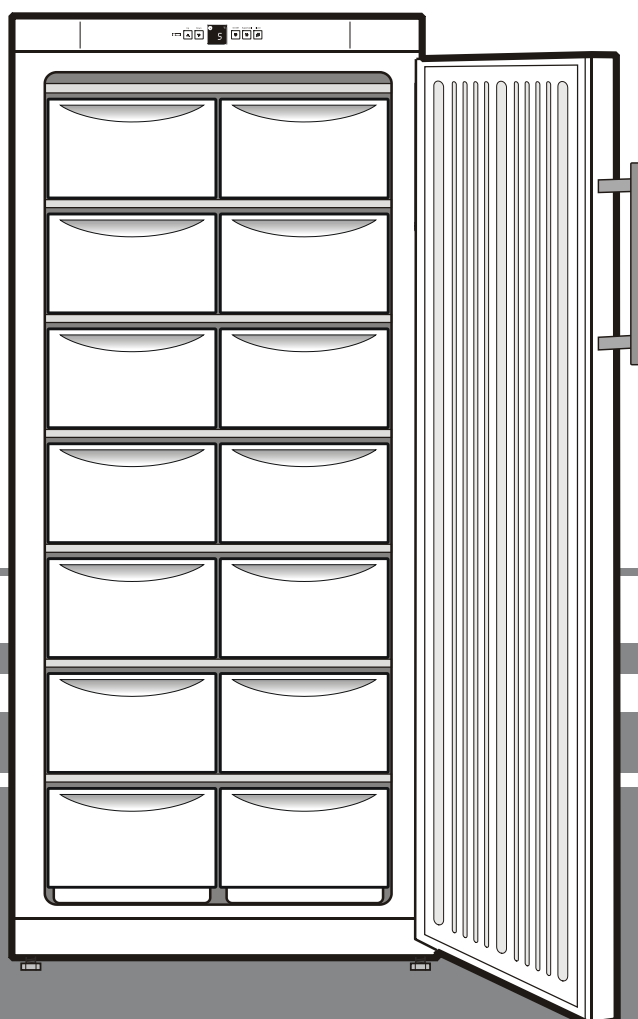

7081 479-00

G 52 912

LIEBHERR

Disposal notes

The appliance contains some reusable materials and should be disposed of properly - not simply with unsorted household refuse. Appliances which are no longer needed must be disposed of in a professional and appropriate way, in accordance with the current local regulations and laws.



When disposing of the appliance, ensure that the refrigeration circuit is not damaged to prevent uncontrolled escape of the refrigerant it contains (data on type plate) and oil.

- Disable the appliance.
- Pull out the plug.
- Cut through the connecting cable.

WARNING

Danger of suffocation due to packing material and plastic film! Do not allow children to play with packing material. Take the packing material to an official collecting point.

Range of appliance use

The appliance is suitable solely for cooling food in a domestic environment or similar. This includes use in, for example

- in staff kitchenettes, bed and breakfast establishments,
- by guests in country homes, hotels, motels and other forms of accommodation,
- in catering and similar services in the wholesale trade.

Use the appliance solely as is customary within a domestic environment. All other types of use are inadmissible. The appliance is not suitable for storing and cooling medicines, blood plasma, laboratory preparations or similar substances and products covered by the 2007/47/EC Medical Devices Directive. Misuse of the appliance can result in the stored products suffering harm or perishing. Furthermore, the appliance is not suitable for operation in potentially explosive atmospheres.

Description of the appliance

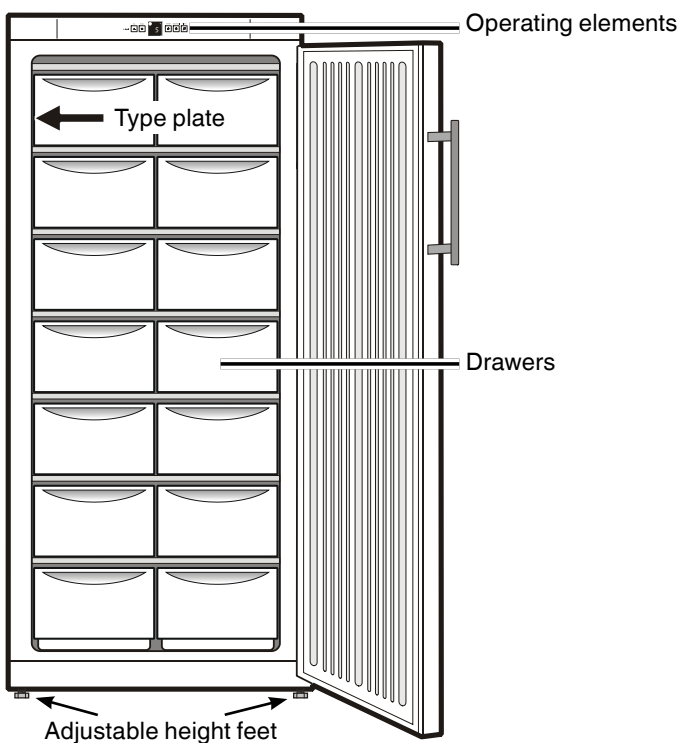

Safety instructions and warnings

- To prevent injury or damage to the unit, the appliance should be unpacked and set up by two people.
- In the event that the appliance is damaged on delivery, contact the supplier immediately before connecting to the mains.
- To guarantee safe operation, ensure that the appliance is set up and connected as described in these operating instructions.
- Disconnect the appliance from the mains if any fault occurs. Pull out the plug, switch off or remove the fuse.
- When disconnecting the appliance, pull on the plug, not on the cable.
- Any repairs and work on the appliance should only be carried out by the customer service department, as unauthorised work could prove highly dangerous for the user. The same applies to changing the mains power cable.
- Do not allow naked flames or ignition sources to enter the appliance. When transporting and cleaning the appliance ensure that the refrigerant circuit is not damaged. In the event of damage, make sure that there are no ignition sources nearby and keep the room well ventilated.
- Do not stand on the plinth, drawers or doors or use them to support anything else.
- This appliance is not intended for use by persons (including children) with reduced physical, sensory or mental capabilities or lack of experience and knowledge unless they have been given initial supervision or instruction concerning use of the appliance by a person responsible for their safety. Children should be supervised to ensure that they do not play with the appliance.
- Avoid prolonged skin contact with cold surfaces or chilled/frozen food. This could cause pain, numbness and frostbite. In the case of prolonged skin contact, protective measures should be taken, e.g. gloves should be worn.
- Do not eat ice cream, particularly ice lollies or ice cubes, immediately after taking them from the freezer compartment as there is a risk of "burning" because of the very cold temperatures.
- Do not consume food which has been stored for too long, as it could cause food poisoning.
- The appliance is designed for freezing and storing food and for making ice and is intended for domestic use. If used for commercial purposes, the relevant legal regulations applicable to the trade concerned must be observed.
- Do not store explosives or sprays using combustible propellants such as butane, propane, pentane etc. in the appliance. Electrical components might cause leaking gas to ignite. You may identify such sprays by the printed contents or a flame symbol.
- Do not use electrical appliances inside the appliance.
- The appliance is designed for use in enclosed areas. Do not operate the appliance outdoors or in areas where it is exposed to splash water or damp conditions.

Climate rating

The climate rating indicates the room temperature at which the appliance may be operated in order to achieve full refrigeration performance.

The climate rating is indicated on the type plate.

The position of the type plate is shown in the section entitled **Description of the appliance**.

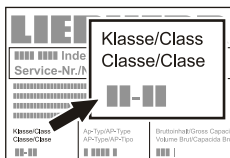

Climate rating	Room temperature
SN	+10°C to +32°C
N	+16°C to +32°C
ST	+16°C to +38°C
T	+16°C to +43°C
SN-ST	+10°C to +38°C
SN-T	+10°C to +43°C

Do not operate the appliance outside the specified room temperature range.

Setting up

- Do not place appliance in areas of direct sunlight or next to a stove, heater or similar object.
- The floor on which the appliance stands should be horizontal and level. Compensate for uneven floors with the adjustable feet.
- Always ensure good ventilation. Do not cover ventilation openings or grille.
- Do not place heat-emitting appliances, e.g. microwave oven, toaster, etc., on top of the freezer.
- Standard EN 378 specifies that the room in which you install your appliance must have a volume of 1 m³ per 8 g of R 600a refrigerant used in the appliance, so as to avoid the formation of inflammable gas/air mixtures in the room where the appliance is located in the event of a leak in the refrigerant circuit. The quantity of refrigerant used in your appliance is indicated on the type plate on the inside of the appliance.
- Always install the appliance directly against the wall.

Dimensions

A= 1725 mm
B= 750 mm
C= 760 mm
D= 1447 mm
E= 790 mm

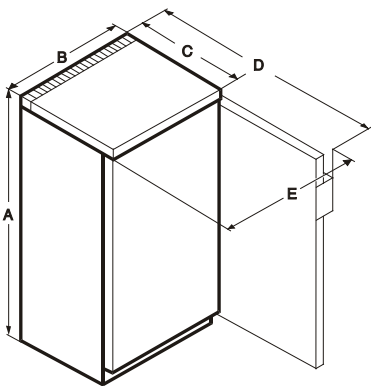

Electrical connection

Only operate the appliance with **alternating current (AC)**.

The permissible voltage and frequency are indicated on the type plate. The position of the type plate is shown in the section entitled **Description of the appliance**.

The socket must be properly earthed and protected by a fuse.

The tripping current of the fuse must be between 10 A and 16 A.

The socket must not be situated behind the appliance and must be easily accessible.

Do not connect the appliance using an extension cable or extension socket.

Do not use stand-alone inverters (conversion of direct current to alternating current/three-phase current) or energy-saving plugs. Risk of damage to the electronic control system!

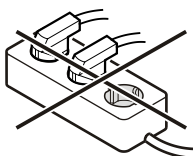

Operating and control elements

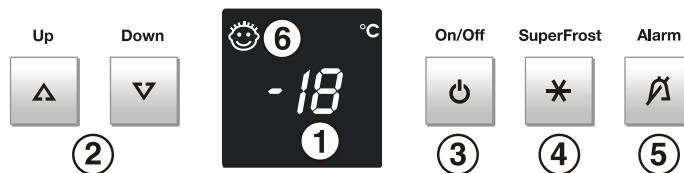

- ① Temperature display
- ② Temperature buttons
- ③ On/Off button
- ④ SuperFrost button
- ⑤ Audible warning on/off button
- ⑥ Child-proof lock

Switching the appliance on and off

Switching on: Press the **ON / OFF** button so that the temperature display lights up/flashes. When the appliance is switched on for the first time and while it is still warm, the display will contain dashes until the temperature falls below 0°C.

On/Off



Switching off: Press the **ON / OFF** button for approx. two seconds so that the temperature display goes out.

Setting the temperature

To increase the temperature

Press the **Up** button.

Up Down



To reduce the temperature

Press the **Down** button.

- When pressing one of the buttons for the first time, the display will start to flash.
- Pressing this button again enables you to change the temperature setting.
- The electronic controls will switch over automatically about 5 seconds after the last time you pressed the button, and the actual temperature will be displayed.
- The temperature can be set at between -14°C and -28°C.

If **F 3** appears in the display, the appliance has a fault. Consult the customer service department indicating the fault number displayed.

Saving energy

- Always ensure good ventilation. Do not cover ventilation openings or grille.
- Do not place appliance in areas of direct sunlight or next to a stove, heater or similar object.
- The energy consumption depends on the installation conditions, e.g. the ambient temperature.
- Keep the time the appliance is open to a minimum.
- Store food logically.
- Ensure that all food is well packed and covered for storage. This will prevent frost from forming.
- First cool warm food to room temperature before storing it.
- If there is a thick layer of frost in the appliance: defrost the appliance.

Accumulated dust increases the energy consumption:

- Once a year, dust the refrigerating unit together with the metal grille of the heat exchanger at the back of the appliance.

Power failure "frost-control" display

If **nA** appears in the display, this means that the freezer temperature has risen too high during the last few hours or days due to a power failure.

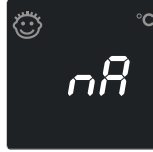

If you press the **ALARM** button whilst the display is reading **nA**, the highest temperature registered during the power failure will be displayed. Check the quality of the food and its suitability for consumption in case it has become too warm or even defrosted.

The highest temperature will appear for approx. 1 minute. After that, the actual temperature in the freezer will re-appear. The display can be switched off by repeatedly pressing the **ALARM** button.

Audible warning signal

Audible door alarm:

This sounds when the door has been left open for longer than about 60 seconds. Press the audible warning on/off button to cancel the alarm. The alarm switches back to standby when the door is shut.

Alarm



Audible/visual temperature alarm:

It sounds when it is not cold enough in the freezer compartment. The temperature display will also flash;

The audible warning device is switched off by pressing the **ALARM** button. The temperature display will continue to flash until the cause of the alarm has been rectified.

This can be caused by:

- the freezer door being left open for a long time, allowing warm ambient air to enter;
- a long power failure;
- a fault in the appliance.

In each case, make sure food has not defrosted or perished.

Additional functions

In set-up mode you can set the child-proof lock and adjust the brightness of the display.

Activating set-up mode:

- Press SuperFrost button for approx. 5 secs - the SuperFrost button flashes - the display shows **c** for child-proof lock. Note: the value to be altered flashes.
- Select the required function by pressing the Up/Down button:
 - c** = child-proof lock, **h** = brightness of the display
- Now select/acknowledge function by pressing SuperFrost button briefly:

> For **c** = **child-proof lock**, press the Up/Down button to select

c1 = child-proof lock on or

c0 = child-proof lock off and acknowledge with the SuperFrost button.

When the symbol  is lit, the child-proof lock is activated.



> For **h** = **brightness**, press Up/Down button to select

h1 = minimum to

h5 = maximum brightness and acknowledge with SuperFrost button.

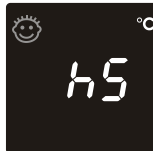

Exit set-up mode:

- Exit the set-up mode by pressing the On/Off button; after 2 min. the electronic system switches over automatically. The normal operating mode is activated again.

Freezing

Fresh food should be frozen to the core as rapidly as possible. Frozen food can also be given a cold boost. This is provided by the "Superfrost" facility.

The maximum amount of food which can be frozen in 24 hours is shown on the type plate ("Freezing capacity ...kg/24 hours"). This amount varies according to the model and climate rating.

Gefriervermogen/Freezing Capacity Pouvoir de Congel./Capac. Congeladora			
kg/24h			
Climate Class	Freezing Capacity	Freezing Capacity	Freezing Capacity
SN-18	18	18	18
SN-19	19	19	19
SN-20	20	20	20
SN-21	21	21	21
SN-22	22	22	22
SN-23	23	23	23
SN-24	24	24	24
SN-25	25	25	25
SN-26	26	26	26
SN-27	27	27	27
SN-28	28	28	28
SN-29	29	29	29
SN-30	30	30	30
SN-31	31	31	31
SN-32	32	32	32
SN-33	33	33	33
SN-34	34	34	34
SN-35	35	35	35
SN-36	36	36	36
SN-37	37	37	37
SN-38	38	38	38
SN-39	39	39	39
SN-40	40	40	40
SN-41	41	41	41
SN-42	42	42	42
SN-43	43	43	43
SN-44	44	44	44
SN-45	45	45	45
SN-46	46	46	46
SN-47	47	47	47
SN-48	48	48	48
SN-49	49	49	49
SN-50	50	50	50
SN-51	51	51	51
SN-52	52	52	52
SN-53	53	53	53
SN-54	54	54	54
SN-55	55	55	55
SN-56	56	56	56
SN-57	57	57	57
SN-58	58	58	58
SN-59	59	59	59
SN-60	60	60	60
SN-61	61	61	61
SN-62	62	62	62
SN-63	63	63	63
SN-64	64	64	64
SN-65	65	65	65
SN-66	66	66	66
SN-67	67	67	67
SN-68	68	68	68
SN-69	69	69	69
SN-70	70	70	70
SN-71	71	71	71
SN-72	72	72	72
SN-73	73	73	73
SN-74	74	74	74
SN-75	75	75	75
SN-76	76	76	76
SN-77	77	77	77
SN-78	78	78	78
SN-79	79	79	79
SN-80	80	80	80
SN-81	81	81	81
SN-82	82	82	82
SN-83	83	83	83
SN-84	84	84	84
SN-85	85	85	85
SN-86	86	86	86
SN-87	87	87	87
SN-88	88	88	88
SN-89	89	89	89
SN-90	90	90	90
SN-91	91	91	91
SN-92	92	92	92
SN-93	93	93	93
SN-94	94	94	94
SN-95	95	95	95
SN-96	96	96	96
SN-97	97	97	97
SN-98	98	98	98
SN-99	99	99	99
SN-100	100	100	100

Freezing with Superfrost

SuperFrost

Press the Superfrost button briefly so that the LED lights up.



- For small amounts of frozen food, it is normally sufficient to switch on Superfrost 6 hours beforehand. For the maximum amount (see freezing capacity on the type plate) you will need to switch it on 24 hours beforehand.
- Then place the fresh food inside the freezer.

Note: The bottom two drawers are not suitable for freezing fresh food. Only pre-frozen food can be stored there.

- The Superfrost function switches off **automatically**. Depending on the quantity of food placed in the freezer, this will normally be between 30 and max. 65 hours.

You should not switch on the Superfrost function:

- when placing frozen food in the freezer;
- when freezing up to approx. 2 kg fresh food daily.

Notes on freezing

- Always store identical food items together.
- Pack food which you are freezing yourself in quantities appropriate to your household. To ensure that the food freezes right through, the following quantities should not be exceeded per package: fruit, vegetables: up to 1 kg, meat: up to 2,5 kg.
- Pack frozen food in standard freezer bags or reusable plastic, metal or aluminium containers.
- Do not allow fresh food which is to be frozen to come into contact with food already frozen. Always keep packs dry in order to avoid them sticking together.
- Always write the date and contents on the pack and do not exceed the stated storage time for the food.
- Do not freeze bottles and cans which contain carbonated drinks as they might burst.
- Only take out as much food as is immediately required for thawing. Use food which has been thawed in prepared meals as quickly as possible.

Frozen food can be thawed in the following ways:

- in a fan oven
- in a microwave oven
- at room temperature
- in the refrigerator: the cold given off by the frozen food is used for cooling.

Defrosting

After a longer period of operation a layer of frost or ice can build up on the cooling plates in the freezer compartment. This will increase the energy consumption of the freezer. The cooling plates should therefore be defrosted regularly.

- Switch the appliance off to defrost. Pull out the mains plug.
- Remove the drawers.
- Wrap the frozen food in paper or blankets and store in a cool place.
- To speed up the defrosting process put a saucepan of hot but not boiling water on one of the cooling elements.
- Leave the door of the appliance open while defrosting. After defrosting mop up the remaining water and clean the appliance.

Do not use any mechanical devices or other artificial aids for defrosting other than those recommended by the manufacturer.

Cleaning

Before cleaning always switch off the appliance. Pull out the mains plug or remove/unscrew the fuse.

Clean the inside, equipment parts and outer walls with lukewarm water and a little detergent. Do not use abrasive or acid cleaners or chemical solvents.

Do not use steam cleaners because of the risk of injury and damage.

- Ensure that no cleaning water penetrates into the electrical components or ventilation grille.
- Dry all parts well with a cloth.
- The dust should be removed from the refrigeration unit and heat exchanger – metal grid at the back of the appliance – once a year.
- Do not damage or remove the type plate on the inside of the appliance. It is very important for servicing purposes.

Malfunctions

You may be able to rectify the following faults by checking the possible causes yourself:

- **Appliance does not function:** the control lamps are not lit.
 - Is the appliance switched on?
 - Is the plug correctly fitted in the mains socket?
 - Is the socket fuse intact?
- **Loud running noise:**
 - Is the appliance set up firmly on the floor?
 - Does the appliance cause nearby items of furniture or objects to vibrate? Please note that noises caused by the refrigerant circuit cannot be avoided.
- **The temperature is not low enough:**
 - Is the temperature setting correct (see "Setting the temperature")?
 - Have excessive amounts of fresh food been placed in the appliance?
 - Does the separately installed thermometer show the correct reading?
 - Is the ventilation system working properly?
 - Is the appliance set up too close to a heat source?

If none of the above causes apply and you cannot rectify the fault yourself, contact the nearest customer service department stating the type of appliance ①, service number ② and appliance number ③ as indicated on the type plate.

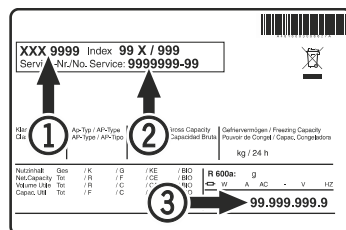

Changing over door hinges

- Remove cover ① .
- Unscrew hinge bracket ② . Remove the door.
- Transfer cover plate ④ to the opposite side.
- Transfer hinge components ③ on the hinge bracket ② to the opposite side.
- Lever out pressure plates ⑤ at the front and slide away.
- Transfer door handles ⑥ and plugs ⑦ to the other side.
- Attach pressure plates ⑤ .
- Transfer plug ⑧ .
- Remove covers ⑩ and ⑪ .
- Transfer pin ⑨ to the opposite side.
- Re-attach covers ⑩ and ⑪ on the opposite side.
- Suspend door on hinge pin ⑨ and close.
- Insert hinge bracket ② in lower door mounting and screw into place.
- Click cover ① into place.

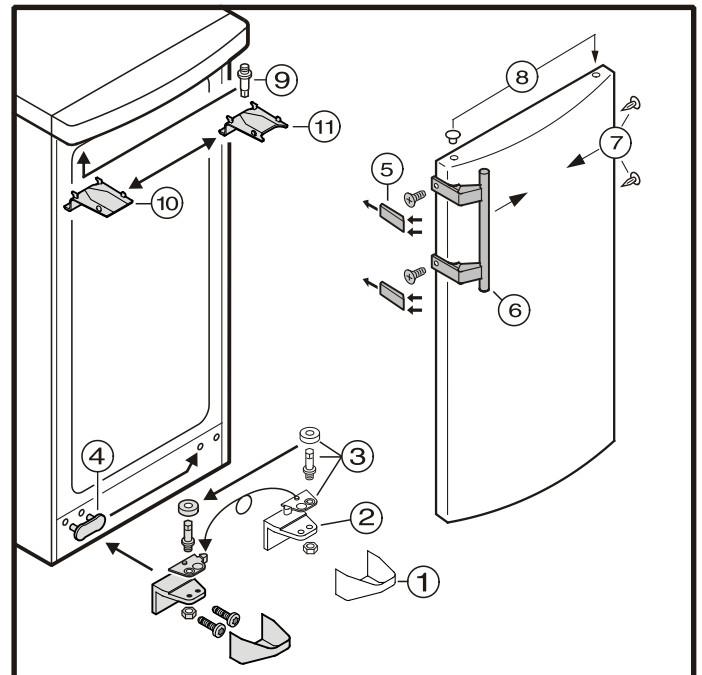

Shutting your appliance down

If your appliance is to be shut down for any length of time, switch it off and disconnect the plug or remove the fuse. Clean the appliance and leave the door open in order to prevent unpleasant smells.

The appliance complies with the relevant safety regulations and EC directives 2004/108/EC and 2006/95/EC.

All types and models are subject to continuous improvement and the manufacturer therefore reserves the right to make modifications to the shape, equipment and technology.