

## Professional Foodservice Equipment 2013

• Catalogue w/o Price list



[www.dynamicmixers.com](http://www.dynamicmixers.com)

*The Original!*



**Dynamic: a long-term experience and a unique professional quality for 50 years.**

## MISCELLANEOUS PRODUCTS p. 28 / 32

### SALAD SPINNER



01 - E10 - 10L.  
H 420 mm - 16,5"  
ø 330 mm - 13"

02 - E20 - 20L.  
H 500 mm - 19,7"  
ø 430 mm - 17"

03 - E20 SC - 20L.  
H 500 mm - 19,7"  
ø 430 mm - 17"

04 - EM electric 20L.  
H 630 mm - 24,8"  
ø 430 mm - 17"

05 - Stabilising base for E 20 and E 20 SC  
H 170 mm - 6,7"  
ø 360 mm - 14"

### MANUAL FOOD CUTTER



01 - Dynacube (+ 1 grid)  
H 330 mm - 13" / ø 400 mm - 15,7"  
Grids: 7x7 / 8,5x8,5 / 10x10 / 14x14 / 17x17 mm

01 - Dynacoupe (+ 2 discs)  
H 260 mm - 10,2" / ø 370 mm - 14,5"  
Dynacoupe discs

### Miscellaneous p. 33/34

- Citrus juicer: Dynajuicer
- Manual food cutter: CF 2000
- Manual whip
- Roadsign cones
- Temperature recording: Dynaclim



**All our products are certified.**

Dynamic's complete product line is in accordance with the essential EU European certifications. In addition, nearly all are certified under UL/ ETL\* regulations with both electrical and sanitation standards. Great care is taken in order to manufacture high quality, sturdy and reliable equipment for the food service industry. \*conforms to all NSF standards.

**All our products are equipped with:**

- Double insulation
- EU approved
- Safety switch
- Variable speed control: standard or option
- Stainless steel bell
- Power cord + plug: Length. 3m / 10ft.

**• Products available in other voltages on request: 115 V or 230 V**

# MINI p. 6 / 10

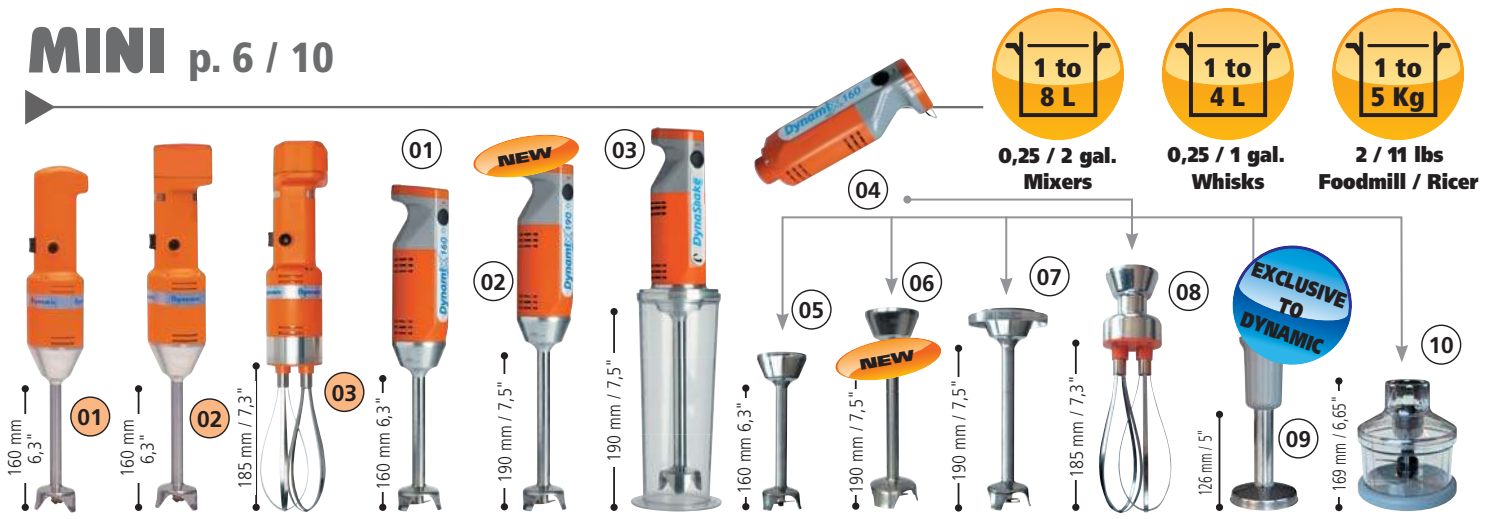

MINI non-detachable p.10

DYNAMIX p.7

01 MD 95 250 W	02 Mini cordless mixer 180 W	03 Mini cordless whisk 180 W	01 & 02 Dynamix 160 / 190 220 W / 250 W	03 Dynashake 250 W	04 Motor block 160 / 190 220 W / 250 W	05 Mixer tools 160 / 190	07 Mixer tool Dynashake	08 Whisk tool	09 Ricer tool	10 Dyna cutter bowl
-------------------	---------------------------------	---------------------------------	--	-----------------------	---	--------------------------	-------------------------	---------------	---------------	---------------------

# JUNIOR p. 12 / 14

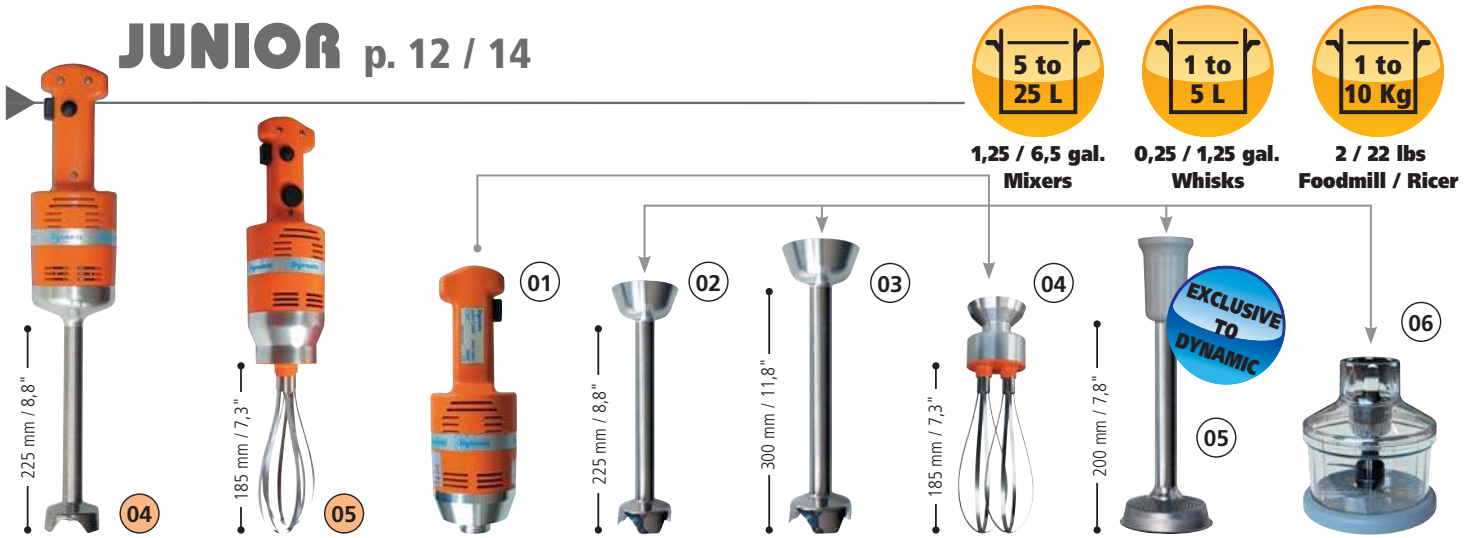

JUNIOR non-detachable p.13

04 Junior standard 270 W	05 Junior Whisk 270 W	01 + 02 Junior Plus 270 W	01 Motor block 270 W	02 Mixer tool	03 Mixer tool XL	04 Whisk tool	05 Ricer tool	06 Dynacutter bowl
-----------------------------	--------------------------	------------------------------	-------------------------	---------------	------------------	---------------	---------------	--------------------

# SENIOR p. 15 / 17

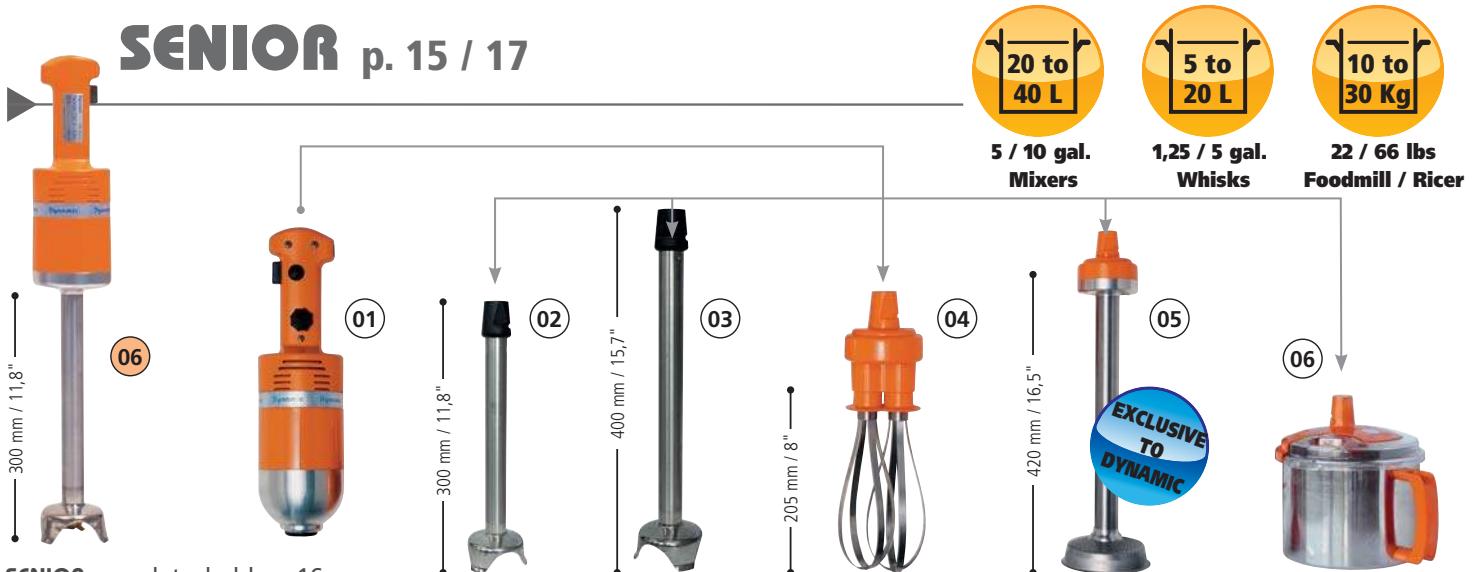

SENIOR non-detachable p.16

06 PMX 98 350 W	01 + 02 PMDH 250 350 W	01 Motor block BM 250 350 W	02 Mixer tool M 250	03 Mixer tool M250 XL	04 Whisk tool F 250	05 Ricer tool	06 Dynacutter bowl
--------------------	---------------------------	--------------------------------	---------------------	-----------------------	---------------------	---------------	--------------------

# MASTER p. 18 / 23

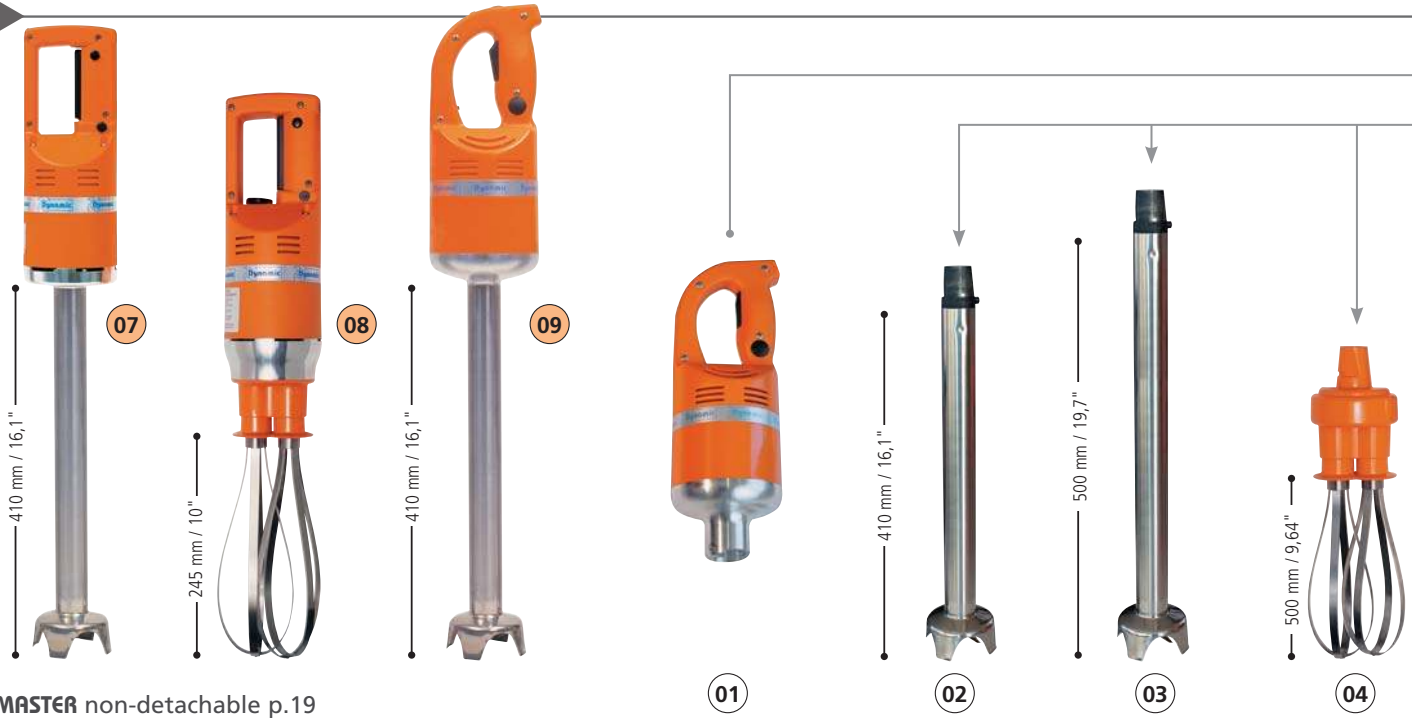

MASTER non-detachable p.19

**07 MX 91**  
500 W

**08 FT 97**  
500 W

**09 MX 2000 standard & DSC**  
500 W

**01 Motor block BM 2000**  
500 W

**02 Mixer tool M 90**

**03 Mixer tool M 500**

**04 Whisk tool F 90**

# SMX p. 24 / 26



15 / 75 gal.



SMX non-detachable p.25

**10 SMX 600 E**  
850 W

**07 SMX 600 DSC**  
850 W

**08 SMX 800E**  
1 000 W

**09 SMX 800 DSC**  
1 000 W

Support brackets: SM - SA (p. 26)



10 / 25 gal.  
Mixers



1,25 / 5 gal.  
Whisks



22 / 66 lbs  
Foodmill / Ricer

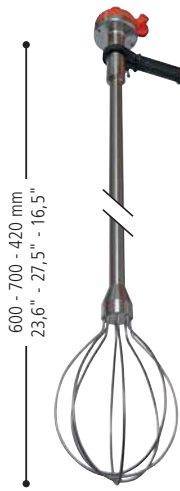

600 - 700 - 420 mm  
23,6" - 27,5" - 16,5"

05



420 mm / 16,5"

06



400 mm / 15,7"

07



08

EXCLUSIVE  
TO  
DYNAMIC



09



10

05 Master beater whisk  
FM 90

05 Master beater whisk  
FM 91

05 Master beater whisk  
FM 92

06 Foodmill /  
Ricer AP 90

07 Emulsifying  
dynaturbo  
attachment

08 Dynacutter  
bowl

09 Stainless  
steel bowl

10 VS  
attachment +  
4 discs + bowl

## PP p. 26



44 / 220 lbs



11



11



450 mm / 17,7"

690 mm / 27,2"



1700 mm / 67"

01

## GIGAMIX p. 27



25 / 75 gal.



02

01 Gigamix  
2,2 kW

02 Whip accessory

RICER / FOODMILL non-detachable p.26

11 PP 97

650 W

11 PP 97 Plus

650 W

## Professional MINI series



### Advantages:

- Ideal for light applications
- Comfortable in use & easy to handle
- Variable speed as standard
- Easy maintenance
- Sealed tube assembly
- Multipurpose blades
- Easy cleaning: perfect hygiene

Scan QR code with your smartphone to view  
MINI series demo videos



## ► Detachable equipment

### A truly professional hand stick blender / mixer for small preparations!

The Dynamix is powerful, quick and efficient with a detachable shaft allowing for simple and easy maintenance. It is the perfect and reliable mixer with easy interchangeable attachments.

## DynamiX 160

Total length:	395 mm / 15,5"
Shaft length:	160 mm / 6,3"
Diameter of the bell:	55 mm / 2,2"
Diameter:	70 mm / 2,8"
Actual / shipping weight:	1 Kg / 2,20 lbs - 1,4 Kg / 3 lbs
Output max:	220 W *
Speed:	0 to 13000 R.P.M.

\*220W (equals approximately 700 W in domestic use)

## DynamiX 190

Total length:	425 mm / 16,7"
Shaft length:	190 mm / 7,5"
Diameter of the bell:	66 mm / 2,6"
Diameter:	70 mm / 2,8"
Actual / shipping weight:	1,2 Kg / 2,6 lbs / 1,5 Kg / 3,3 lbs
Output max:	250 W *
Speed:	0 to 13000 R.P.M.

\*250W (equals approximately 750 W in domestic use)

## DynaShake

The Dynashake, with its graduated bowl makes - with ease and at a great speed, the perfect milkshakes, smoothies and cocktails.

Total length:	425 mm / 16,7"
Shaft length:	190 mm / 7,5"
Diameter:	95 mm / 3,7"
Actual / shipping weight:	1,4 Kg / 3 lbs - 1,5 Kg / 3,3 lbs
Output max:	250 W *
Speed:	0 to 13000 R.P.M.

\*250W (equals approximately 750 W in domestic use)



01 **DynamiX 160 detachable** Ref. MX050

Dynamix 160 standard with emulsifying knife

02 **DynamiX 190 detachable** Ref. MX090

Dynamix 190 standard with emulsifying knife

03 **DynaShake® detachable** Ref. MX051

Dynashake standard with emulsifying knife + beaker with cover

# The accessories of **DynamiX**



**Mixer**      **Whisks**      **Foodmill / Ricer**

**0,25 / 2 gal.**    **0,25 / 1 gal.**    **2 / 11 lbs**

**02**      **03**      **04**      **05**

160 mm / 6,3"      190 mm / 7,5"      190 mm / 7,5"      185 mm / 7,3"

**Standard knife**  
2 blades  
Ref. 0551

**Emulsifying knife**  
4 blades  
Ref. 0550

**Beater disc**  
Ref. 0552

**Smoothie emulsifying disc**  
Ref. 0553

**Detachable whisks**

01	<b>160 standard motor block</b>	Ref. AC515
01	<b>190 standard motor block</b>	Ref. AC514

**Accessories** (sold separately)

02	<b>160 attachment with emulsifying knife - 4 blades</b>	Ref. AC520
03	<b>190 Attachment with emulsifying knife - 4 blades</b>	Ref. AC550
04	<b>Watertight attachment with emulsifying knife - 4 blades</b>	Ref. AC530

05	<b>Whisk tool 185 mm - 1 to 5 L</b>	Ref. AC516
06	<b>Foodmill ricer 126 mm - 1 to 5 Kg</b>	Ref. AC517
07	<b>Cutter bowl 0,8 l.</b>	Ref. AC518
08	<b>Graduated beaker 1l. + cover</b>	Ref. AC510
09	<b>Stainless steel jug 3 l. - H: 18 cm, ø: 15 cm - Suitable for all cooking surfaces including induction</b>	Ref. AC513

	<b>Blade pack includes: emulsifying cutter blade + standard blade + beater disc + emul. disc</b>	Ref. AC540
--	--	------------



- 2500 RPM
- Reverse sharpening blades

### Dynamix pack

Ref. MX052

Dynamix pack includes:

- 1 Dynamix 160 + 1 emulsifying blade + 1 standard blade + 1 beater disc + 1 smoothie emulsifying disc + a 1-litre-graduated beaker + cover

### DynaShake® pack

Ref. MX054

- Dynashake pack includes: 1 Dynashake + 1 emulsifying blade + 1 standard blade + 1 beater disc + 1 smoothie emulsifying disc + a 1-litre-graduated beaker + cover

### 10 Dynamix MFAP pack

Ref. MF050

MFAP pack includes:

- 1 Dynamix 160 with emulsifying blade + 1 whisk tool + 1 ricer tool.

### 11 Dynamix MF pack

Ref. MF052

MF pack includes:

- 1 Dynamix 160 with emulsifying blade + 1 whisk tool

# MINI series

## ► Non-detachable equipment

Our MINI range is powerful, reliable and easy to use. Standard or cordless, they are ideal for preparing small amounts of soups and sauces.

With their small size they will offer freedom, power and versatility for professionals at work.

The MINI cordless stick blenders / mixers are unique products within the market and they are supplied with charger and a long lasting battery.



0,25 / 2,5 gal.



Battery pack and charger included



0,25 / 1,25 gal.

A stainless steel wall support included

01 **MD 95 Standard blade** Ref. MX010

**MD 95 E Emulsifying blade** Ref. MX008

MD 95 and MD 95 E capacity 4 to 12 litres / 1 to 3 gal.

Total length: ..... 445 mm / 17,5"  
 Mixer tool length: ..... 160 mm / 6,3"  
 Diameter: ..... 72 mm / 2,8"  
 Actual weight / shipping weight: 1,2 Kg / 2,6 lbs - 1,5 Kg / 3,3 lbs  
 Output max: ..... 250 W  
 Speed: ..... 11500 R.P.M.

**Option: variable speed control** Ref. AC040

**Emulsifying knife (4 blades)** 06 Ref. 9414

02 **Cordless MINI mixer with emulsifying blade \*** Ref. MX014

**Cordless MINI mixer \*** Ref. MX011

Capacity 1 to 5 litres / 0,25 to 1,25 gal.

Total length: ..... 460 mm / 18,1"  
 Mixer tool length: ..... 160 mm / 6,3"  
 Diameter: ..... 72 mm / 2,8"  
 Actual weight / shipping weight: 1,4 Kg / 3,0 lbs - 3,0 Kg / 6,6 lbs  
 Speed: ..... 7000 R.P.M.

03 **Cordless MINI whisk \*** Ref. FT003

Total length: ..... 445 mm / 17,5"  
 Whisk tool length: ..... 185 mm / 7,3"  
 Diameter: ..... 72 mm / 2,8"  
 Actual weight / shipping weight: 1,5 Kg / 3,3 lbs - 3,0 Kg / 6,6 lbs  
 Speed: ..... 700 R.P.M.

**Accessories** (sold separately)

04 **PB MINI. New technology Ni-Mh - Autonomy 1hr.** Ref. AC111

05 **Charger C MINI. Charger 115 V or 230 V - Run time 2hrs.** Ref. AC110

06 a 4-blade-emulsifying knife - Ref. 9414



"L'Ecole du Grand Chocolat Valrhona school is 20 years old and has become iconic in the world of professional training, specialising in the work of chocolate.

Our technical work of Chocolate emulsifying requires efficient, reliable and robust tools. The Dynamic mixer, with its special blade offers us ease of use and perfect results in our specialist training programme."

**Frédéric Bau**

Head Chef - Designed manager of the "Grand Chocolat VALRHONA" school.

\*Subject to stock availability

Attractive packaging for a greater impact in-store.



Enhanced selling feature



Dynamix MFAP pack



Special offer, pallet display



Special offer, display stand



## Professional JUNIOR series

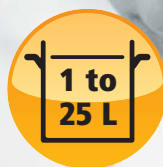

### Advantages:

- Easy to handle and powerful
- Easy maintenance
- Additional accessories (sold separately)
- Variable speed as standard or optional

Scan QR code with your smartphone to view  
JUNIOR series demo videos



## ► Non-detachable equipment

The JUNIOR range is ideal in preparations with a maximum capacity of 25 litres / 6.5 gallons.



a 4-blade-emulsifying knife - Ref. 4009



1,25 / 6,5 gal.



Option



0,25 / 1,25 gal.



**Convenient and secure:** Wall storage bracket included.

Ref. 089959



Ref. 0880.1

### 01 JUNIOR Standard non-detachable Ref. MX020

Total length: ..... 505 mm / 19,8"  
 Mixer tool length: ..... 225 mm / 9"  
 Diameter: ..... 94 mm / 3,7"  
 Actual weight / shipping weight: 1,7 Kg / 3,7 lbs - 2,0 Kg / 4,4 lbs  
 Output max:: ..... 270 W  
 Speed: ..... 11000 R.P.M.

### Emulsifying knife (4 blades) 03 Ref. 4009

Option: variable speed control Ref. AC040

### 02 JUNIOR whisk non-detachable Ref. FT005

Total length: ..... 500 mm / 19,7"  
 Mixer tool length: ..... 185 mm / 7,3"  
 Diameter: ..... 94 mm / 3,7"  
 Actual weight / shipping weight: ...1,4 Kg / 3 lbs - 1,7 Kg / 3,7 lbs  
 Output max: ..... 270 W  
 Speed: ..... 0 to 2000 R.P.M.

## ► Detachable equipment

**Mixer** 1,25 / 6,5 gal.    **Whisks** 0,25 / 1,25 gal.    **Foodmill / Ricer** 2 / 22 lbs



### JUNIOR Plus detachable

01 + 02

Ref. MX021.V

Total length: ..... 505 mm / 19,8"  
 Mixer tool length: ..... 225 mm / 9"  
 Diameter: ..... 94 mm / 3,7"  
 Actual weight / shipping weight: 1,9 Kg / 4,2 lbs - 2,3 Kg / 5 lbs  
 Output max: ..... 270 W  
 Speed: ..... 0 to 11000 R.P.M.

### JUNIOR packs

#### JUNIOR Plus XL detachable

01 + 03

Ref. MX024

Mixer tool detachable 300 mm / 11,8"

### JUNIOR Plus Combi

01 + 02 + 04

Ref. MX022

Mixer tool 225 mm / 9" + whisk tool 185 mm / 7,3"

### Accessories (sold separately)

01	<b>JUNIOR motor block</b>	Ref. AC100
02	<b>JUNIOR mixer tool detachable 225 mm / 9"</b>	Ref. AC101
03	<b>JUNIOR XL extended mixer tool detachable 300 mm / 11,8"</b>	Ref. AC105
04	<b>JUNIOR whisk tool 185 mm / 7,3"</b>	Ref. AC102
05	<b>JUNIOR ricer tool 1 to 10 Kg / 0,25 to 1,25 lbs</b>	Ref. AC103
06	<b>Cutter bowl 0,8 l.</b>	Ref. AC104



## Professional SENIOR series

### Advantages:

- Ideal for medium size applications
- Top quality materials
- New improved waterproof seal
- Easy maintenance
- Additional accessories (sold separately)
- Variable speed standard or optional

Scan QR code with your smartphone to view  
SENIOR series demo videos



# SENIOR series

## ► Non-detachable equipment

Our SENIOR range offers power and versatility. They are ideal for medium to large capacity mix, and the most delicate recipes.

5 / 10 gal.

Option



01

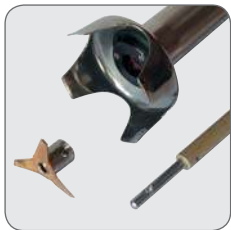

- Easily dismantled without any special tool.
- Reinforced seal (attached double lip), specially coated lines with anti-oxidation (anodising) for a perfect hygiene.

Ref. 0880



**Convenient and secure:**

Wall storage bracket for mixer and accessories included.



**Mixer**  
5 / 10 gal.



**Whisks**  
1 / 5 gal.



**Foodmill / Ricer**  
22 / 66 lbs

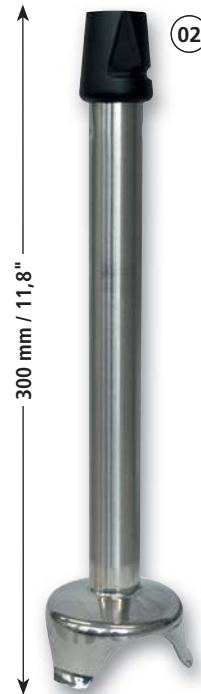

02

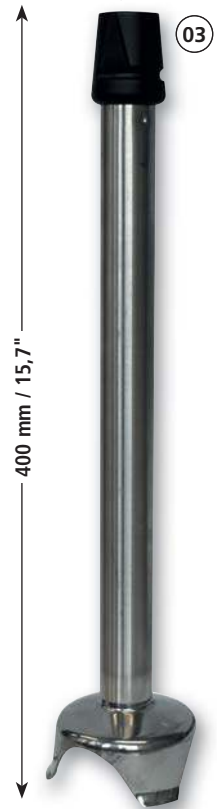

03

**Extended mixer tool**  
400 mm / 15,7"

### 01 PMX 98 Standard non-detachable

Ref. MX007

Total length: ..... 600 mm / 23,6"  
 Mixer tool length: ..... 300 mm / 11,8"  
 Diameter: ..... 97 mm / 3,8"  
 Actual weight / shipping weight: 2,4 Kg / 5,3 lbs - 2,9 Kg / 6,4 lbs  
 Output max: ..... 350 W  
 Speed: ..... 9500 R.P.M.

**PMX option: variable speed control**

Ref. AC040

### PMDH 250 detachable

Ref. MX006

01 + 02

Total length: ..... 640 mm / 25,2"  
 Mixer tool length: ..... 300 mm / 11,8"  
 Diameter: ..... 97 mm / 3,8"  
 Actual weight / shipping weight: 2,5 Kg / 5,5 lbs - 3,7 Kg / 8,1 lbs  
 Output max: ..... 350 W  
 Speed: ..... 0 to 9500 R.P.M.

## ► Detachable equipment

# SENIOR



Precise alignment of motor block and mixer tool requires only a 1/4 turn to secure.

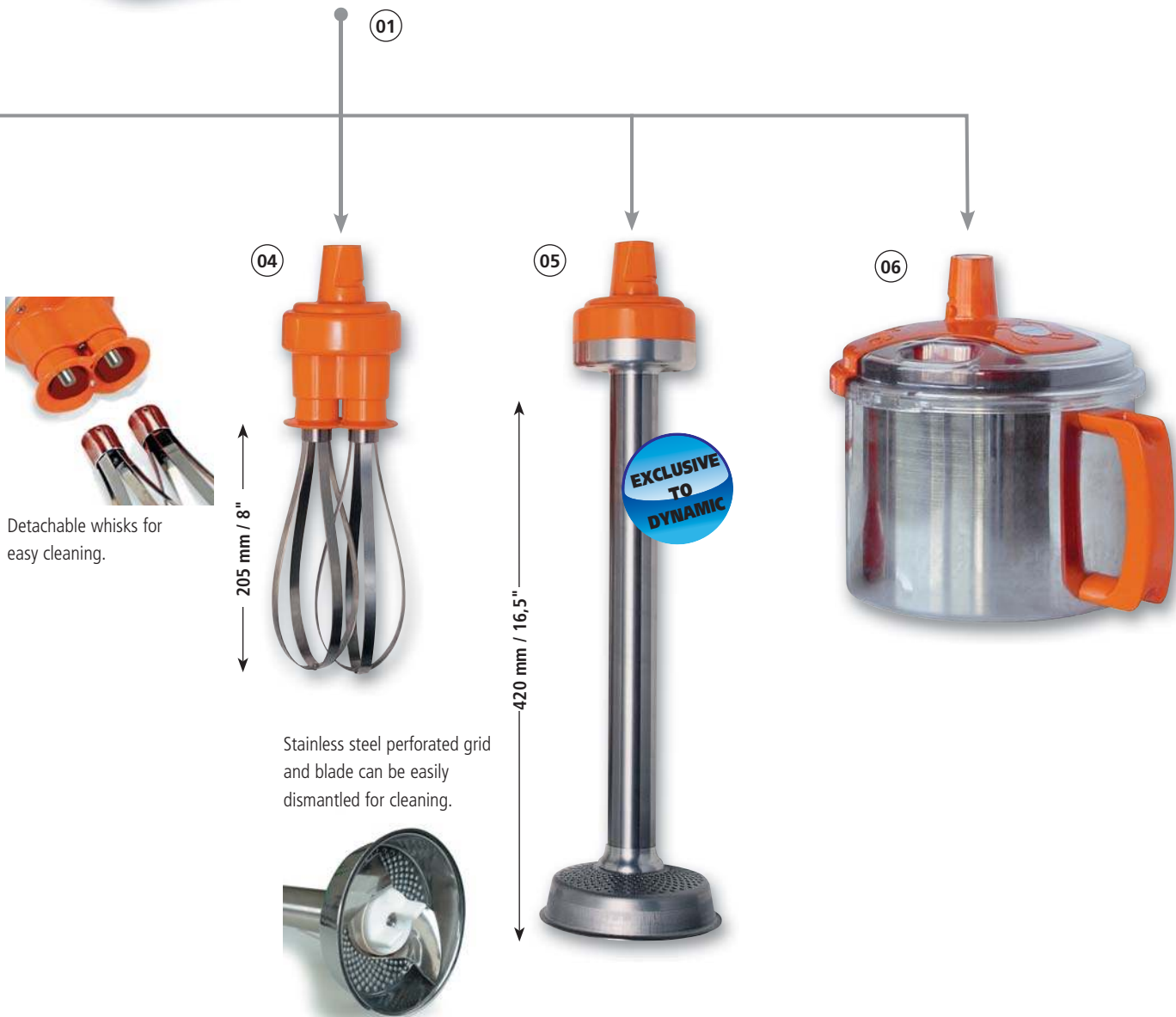

### PMDH 250 XL detachable

01 + 03

Ref. MX016

### SENIOR packs

#### PMF 250 Combi pack

01 + 02 + 04

Ref. MF003

Mixer tool 300 mm / 11,8" + Whisk tool 205 mm / 8"

#### MF 250 Combi XL pack

01 + 03 + 04

Ref. MF015

Mixer tool 400 mm / 15,7" + Whisk tool 205 mm / 8"

### SENIOR accessories (sold separately)

01 **Motor block BM 250** Ref. AC005

02 **Mixer tool M 250 - 300 mm / 11,8"** Ref. AC006

03 **Mixer tool M 250 XL - 400 mm / 15,7"** Ref. AC016

04 **Whisk tool F 250 - 205 mm / 8"** Ref. AC007

05 **Ricer tool - 420 mm / 16,5"** Ref. AC004

Capacity: 10 to 30 Kg / 22 to 66 lbs

06 **Complete stainless steel cutter bowl** Ref. AC055

Capacity: 5 L.

## Professional MASTER series



### Advantages:

- Versatility: wide range of attachments
- Powerful mixers / stick blenders
- Durable top quality materials
- Variable speed as standard
- Easy maintenance
- Easy to use and clean
- Ergonomic design



Scan QR code with your smartphone to view  
MASTER series demo videos



## ► Non-detachable equipment

Our MASTER Mixer Range is the most advanced and versatile in the professional catering industry.

The units are strong and dependable, perfect for containers holding up to 100 litres / 25 gallons.

Our wide variety of attachments in the MASTER range, adds versatility and flexibility, to your food preparation needs.



05 a 4-blade-emulsifying knife - Ref. 7910



10 / 25 gal.



Option

### 01 MX 91 Non-detachable Ref. MX005

Total length: ..... 715 mm / 28"  
 Mixer tool length: ..... 410 mm / 16"  
 Diameter: ..... 110 mm / 4,3"  
 Actual weight / shipping weight: 3,4 Kg / 7,5 lbs - 3,8 Kg / 8,4 lbs  
 Output max: ..... 500 W  
 Speed: ..... 9500 R.P.M.

### MX91 option: variable speed control Ref. AC040

### 02 FT 97 Non-detachable Ref. FT001

Total length: ..... 650 mm / 25,6"  
 Whisk length: ..... 245 mm / 9,7"  
 Diameter: ..... 110 mm / 4,3"  
 Actual weight / shipping weight: 3,3 Kg / 7,3 lbs - 3,7 Kg / 8,1 lbs  
 Output max: ..... 500 W  
 Speed: ..... 300 to 900 R.P.M.

### Emulsifying knife (4 blades) 05 Ref. 7910

### 03 MX 2000 Standard non-detachable Ref. MX004

Total length: ..... 720 mm / 28,4"  
 Mixer tool length: ..... 410 mm / 16"  
 Diameter: ..... 122 mm / 4,8"  
 Actual weight / shipping weight: ...3,5 Kg / 7,7 lbs - 4,1 Kg / 9 lbs  
 Output max: ..... 500 W  
 Speed: ..... 9500 R.P.M.

### Option: variable speed control Ref. AC040

### 04 MX 2000 DSC (Dyna Speed Control) or Ref. MX030 (230V - 50Hz) Ref. MX030.2 (230V - 60Hz)

Total length: ..... 720 mm / 28,4"  
 Mixer tool length: ..... 410 mm / 16"  
 Diameter: ..... 122 mm / 4,8"  
 Actual weight / shipping weight: .....3,5 Kg / 7,7 lbs - 4 Kg / 9 lbs  
 Output max: ..... 500 W  
 Speed: ..... 3000 to 9500 R.P.M.



Detachable whisks for easy cleaning.



## Dyna Speed Control

Self regulating speed - Adds longevity to all components.



9500 R.P.M.



9500 R.P.M.

# MASTER series

## ► Detachable equipment

**10 ATTACHMENTS FOR 1 MOTOR BLOCK gives you unparalleled preparation flexibility.**

# Master Combi



You can attach multiple accessories to the BM2000 motor block. Sold separately or as a package, this innovative solution replaces many machines and frees up work surface space.



**Mixer**  
10 / 25 gal.



**Whisks Foodmill / Ricer**  
1,25 / 5 gal. 22 / 66 lbs



### MASTER accessories (sold separately)

01 **BM 2000 motor block** Ref. AC001

Length: ..... 350 mm / 13,8"  
Diameter: ..... 122 mm / 4,8"  
Output max: ..... 500 W  
Voltage: ..... 230 V or 115 V  
Speed: ..... 3000 to 9500 R.P.M. with variable speed

02 **Mixer tool M 90** Ref. AC002

Capacity: 20 - 100 litres / 5 - 25 gal.

03 **Mixer tool M 500** Ref. AC500

Capacity: 20 - 100 litres / 5 - 25 gal.  
Length: 500 mm / 19,7"

04 **Whisk tool F 90** Ref. AC003

Capacity: 5 - 20 litres / 1,25 - 5 gal.  
Speed: 300 to 900 R.P.M. with variable speed control

05 **MASTER beater whisk FM 90** Ref. AC200

Length: 600 mm / 23,6"

05 **MASTER beater whisk FM 91** Ref. AC201

Length: 700 mm / 27,6"

05 **MASTER beater whisk FM 92** Ref. AC202

Length: 420 mm / 16,5"

Capacity: 20 - 200 litres / 5 - 50 gal.  
Speed: 100 to 500 R.P.M.  
All stainless steel, handle support included.  
**Manual whip FMA 90:** see page 34

01



07



+

08



09



10



**06 AP 90 Foodmill / Ricer** Ref. AC004

Capacity: 10 to 30 Kg / 22 to 66 lbs  
Diameter grid: 110 mm / 4,3"  
Speed: 100 to 600 R.P.M. with variable speed control

**07 Emulsifying dynaturbo attachment** Ref. AC050

Capacity: 5 litres / 1,25 gal.  
Length: 400 mm / 15,7"

The emulsifying Dynaturbo attachment: generally used for ice-creams and sorbets, finely purees fresh or thawed ingredients which have been processed with the M90 mixer tool attachment. Supplied with two heads: one for fruit and one for creams or syrups. Can be completely dismantled for perfect cleaning.

**08 Dynacutter Bowl complete** Ref. AC055

The complete Dynacutter bowl includes a 5-litre / 6 QTS -bowl and its cover, a standard blade or a serrated blade. (See technical characteristics on page 23.)

**09 Dynacutter Bowl only** Ref. 9073

Dynacutter bowl only, without cover or blade. Used as base for VS attachment, or simply as an extra bowl. (See technical characteristics on page 23.)

**10 VS Attachment + 4 discs**

Without bowl support Ref. AC125

With bowl support Ref. AC126

(See sizes p. 23)

# MASTER series



**Convenient and secure:**  
Wall storage bracket for mixer and accessories included.  
Ref. 0880

Mixer	Whisks	Foodmill / ricer
10 / 25 gal.	2,5 / 5 gal.	65 lbs



- Easily dismantled without any special tool.
- Reinforced seal (attached double lip), specially coated lines with anti-oxidation (anodising).
- Blades specially sharpened to guarantee optimum cutting quality



Continuous auto run button allows to mix continuously or pulse.



Detachable whisks for easy cleaning.



**EXCLUSIVE TO DYNAMIC**

02



03



04

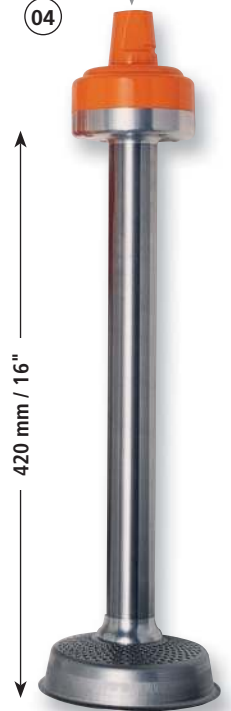

## MASTER packs

### MDH 2000 Plus detachable mixer

Ref. MX003

01 + 02

Total length: ..... 720 mm / 28,3"  
Mixer tool length: ..... 410 mm / 16"  
Diameter: ..... 122 mm / 4,8"  
Actual weight / shipping weight: .3,7 Kg / 8,1 lbs - 4,5 Kg / 9,9 lbs  
Output max: ..... 500 W  
Speed: ..... 3000 to 9500 R.P.M.

### MF 2000 Combi (Mixer + whisk tools)

Ref. MF002

01 + 02 + 03

Total length: ..... 753 mm / 29,6"  
Mixer tool length: ..... 410 mm / 16"  
Whisk tool length: ..... 245 mm / 9,6"  
Diameter: ..... 122 mm / 4,8"  
Actual weight / shipping weight: 4,5 Kg / 9,9 lbs - 6,3 Kg / 3,9 lbs  
Output max: ..... 500 W  
Mixer / Whisk Speed:: .....3000 to 9500 - 300 to 900 R.P.M.

### MFAP 2000 detachable (Mixer + whisk + ricer tools)

Ref. MF001

01 + 02 + 03 + 04

Total length: ..... 753 mm / 29,6"  
Mixer tool length: ..... 410 mm / 16"  
Whisk tool length: ..... 245 mm / 9,6"  
Length and diameter of ricer / foodmill: 420 mm - 110 mm  
Diameter: ..... 122 mm / 4,8"  
Actual weight / shipping weight: 6,5 Kg / 14,3 lbs - 8,4 Kg / 18,5 lbs  
Output max: ..... 500 W  
Mixer speed: ..... 3000 to 9500 R.P.M.  
Whisk speed: ..... 300 to 900 R.P.M.  
Foodmill/ricer speed: ..... 100 to 600 R.P.M.



Stainless steel perforated grid and blade can be easily dismantled for cleaning.



A 5-litre-  
stainless-  
steel bowl

01

## Cutter



### 01 Dynacutter complete

Ref. MF010

Total weight: ..... 5 Kg / 11 lbs - 6 Kg / 13,2 lbs  
Output max: ..... 500 W

The Dynacutter includes: the BM 2000 motor block, a complete stainless steel bowl with your choice of a standard or a serrated blade.

**Standard blade** Ref. 9072

**Serrated blade** Ref. AC056

### 02 VS Attachment complete

Ref. MF012

Total weight: ..... 7 Kg / 15,4 lbs - 8 Kg / 17,6 lbs  
Output max: ..... 500 W

Includes: BM 2000 motor block (bowl used as support only), VS attachment with 2 shredding discs (2 & 3 mm, 5/64"-1/8") + 2 slicing discs (2 & 3 mm, 5/64"-1/8") + a sling plate.

### 03 Multi-Function Food Prep System

Ref. MF014

Total height Dynacutter: ..... 600 mm / 23,6"  
Total height VS attachment: ..... 650 mm / 25,6"  
Diameter of bowl: ..... 220 mm / 8,7"  
Total weight: ..... 8 Kg / 17,6 lbs - 9 Kg / 19,8 lbs  
Voltage: ..... 115 V or 230 V  
Output max: ..... 500 W  
Speed: ..... 0 to 1500 R.P.M.

Multi-function food prep system consists of:

- BM 2000 motor block,
- Complete Dynacutter bowl with one blade of your choice,
- VS attachment with 4 discs + an ejector disc.

#### Additional discs sold separately

**Specific discs** - cutting: 10 x 10 mm - 3/8" (not shown)

**Dicing kit** Ref. AC170

**Julienne disc** Ref. AC175

#### 04 Slicing discs - Cutting thickness

**1,5 mm x Ø 220 mm - 1/64"** Ref. AC151

**2 mm x Ø 220 mm - 5/64"** Ref. AC152

**3 mm x Ø 220 mm - 1/8"** Ref. AC153

**5 mm x Ø 220 mm - 3/16"** Ref. AC155

#### 05 Shredding discs

**Ø holes - 2 mm x Ø 220 mm - 5/64"** Ref. AC162

**Ø holes - 3 mm x Ø 220 mm - 1/8"** Ref. AC163

**Ø holes - 4 mm x Ø 220 mm - 5/32"** Ref. AC164

02

## Complete VS attachment



Standard blade  
Ref. 9072



Serrated blade  
Ref. AC056



## Multi-function

03



04

05

**Professional  
SMX series  
Foodmill / ricer series**



**Advantages:**

- Ideal for larger volumes
- Powerful heavy duty mixers
- High performance motor
- Stainless steel handle support for ease of operation
- Stainless steel attachment



Scan QR code with your smartphone to view  
SMX AND FOODMILL RICER  
series demo videos



Ultimate power! Our super stick blenders / mixers in our SMX range, from the SMX 600 E to our SMX 800 DSC, offer the ultimate in performance and power. Our new cooling technology ensures longer life to your mixer. They are ideal for mass catering, institutions, canteens etc...



Mixer support brackets. For a safe and secure work environment (p. 26).

**01 SMX 600 E Non-detachable** Ref. MX002

Total length: ..... 800 mm / 31,5"  
 Mixer tool length: ..... 530 mm / 20,8"  
 Diameter: ..... 125 mm / 4,9"  
 Actual weight / shipping weight: ..6,1 Kg / 13,4 lbs - 7,7 Kg / 17 lbs  
 Voltage: ..... 115 V or 230 V  
 Output max: ..... 850 W  
 Speed: ..... 9500 R.P.M.

**02 SMX 600 DSC detachable** Ref. MX035

Total length: ..... 870 mm / 34,2"  
 Mixer tool length: ..... 600 mm / 23,6"  
 Diameter: ..... 125 mm / 4,9"  
 Actual weight / shipping weight: ..6,5 Kg / 14,3 lbs - 8 Kg / 17,6 lbs  
 Voltage: ..... 115 V or 230 V  
 Output max: ..... 850 W  
 Speed: ..... 9500 R.P.M.

**03 SMX 800 E detachable** Ref. MX001

Total length: ..... 950 mm / 37,4"  
 Mixer tool length: ..... 680 mm / 26,7"  
 Diameter: ..... 125 mm / 4,9"  
 Actual weight / shipping weight: ..6,7 Kg / 14,7 lbs - 8,2 Kg / 18 lbs  
 Voltage: ..... 115 V or 230 V  
 Output max: ..... 1000 W  
 Speed: ..... 9500 R.P.M.

**04 SMX 800 DSC detachable** Ref. MX034

Total length: ..... 950 mm / 37,4"  
 Mixer tool length: ..... 680 mm / 26,7"  
 Diameter: ..... 125 mm / 4,9"  
 Actual weight / shipping weight: ..6,7 Kg / 14,7 lbs - 8,2 Kg / 18 lbs  
 Voltage: ..... 115 V or 230 V  
 Output max: ..... 1000 W  
 Speed: ..... 9500 R.P.M.

**Dynaturbo SMX 800E motor block** Ref. AC052

**05 Dynaturbo tool for SMX 800E** Ref. AC050.5

Mixer tool length: ..... 370 mm / 14,5"  
 Weight: ..... 1,5 Kg / 3,3 lbs

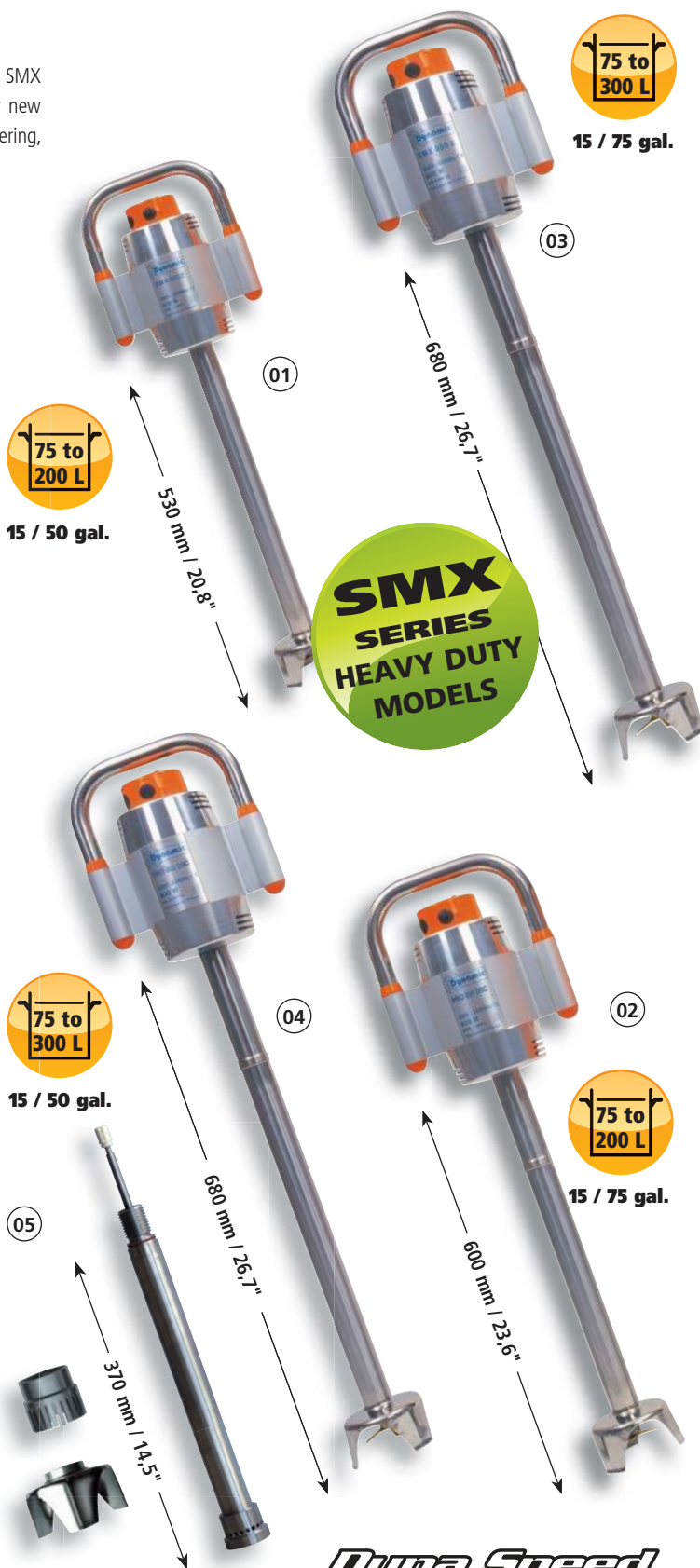

**Dyna Speed Control**

Self regulating speed - Adds longevity to all components.



9500 R.P.M.

9500 R.P.M.

# RICER / FOODMILL

series



44 - 220 lbs



06

520 mm / 20,5"



07

570 mm / 22,4"

450 mm / 17,7"



06 **PP 97 Ricer / Foodmill non-detachable 520 mm - 20,5"** Ref. PP001

07 **PP 97 Plus Ricer / Foodmill detachable 570 mm - 22,5"** Ref. PP002

Total length PP97 - PP97+: ... 870 - 920 mm / 34,2" - 36,2"  
 Mixer tool length PP97 - PP97+: 520 - 570 mm / 20,5" - 22,5"  
 Diameter: ..... 170 mm / 6,7"  
 Actual weight / shipping weight: 4,9 Kg / 10,7 lbs - 5,9 Kg / 13 lbs  
 Voltage: ..... 115 V or 230 V  
 Output max: ..... 650 W  
 Speed PP97 - PP97+: ..... 500 R.P.M. - 100 to 500 R.P.M.

### Accessories (sold separately)

**BM 97 Motor block only** Ref. AC221

Length: 350 mm / 13,8" - Weight: 3 Kg / 6,6 lbs -  
 Speed: 100 to 500 R.P.M. - Output max: 650 Watts

**AP 97 Ricer tool** Ref. AC220

Length: 450 mm / 11,7" - Weight: 1,9 Kg / 4,2 lbs - Capacity: 30 Kg / 66 lbs

08 **FM 97 Whisk tool** Ref. AC208

Length: 690 mm / 27,2" - Weight: 1,5 Kg / 3,3 lbs -  
 Capacity: 40 to 100 l. / 10 to 26 gal. - comes with handle

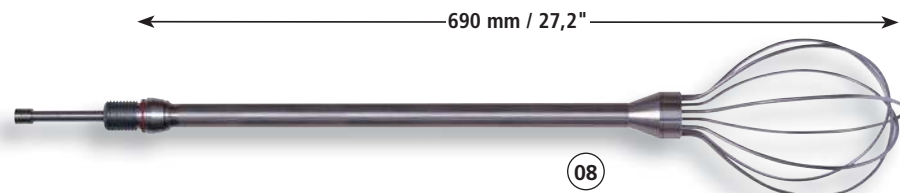

08



09

They are easily dismantled.  
 Adaptable to all types of mixers.  
 Adjustable length. Practical and  
 convenient, allows adjustable  
 height and angle.

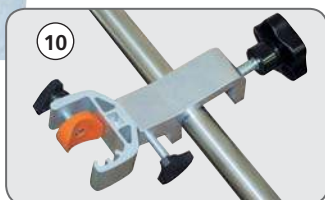

10

### Pan support brackets

09 **SM 4** Ref. SM001

Maximum support bracket diameter: ..... 400 mm / 15,7"  
 Weight: ..... 1,9 Kg / 4,2 lbs

09 **SM 6** Ref. SM002

Maximum support bracket diameter: ..... 600 mm / 23,6"  
 Weight: ..... 2,3 Kg / 5 lbs

09 **SM 8** Ref. SM003

Maximum support bracket diameter: ..... 800 mm / 31,5"  
 Weight: ..... 2,6 Kg / 5,7 lbs

09 **SM 10** Ref. SM004

Support bracket maximum diameter: ..... 1000 mm / 39,4"  
 Weight: ..... 2,8 Kg / 6,2 lbs

09 **SM 12** Ref. SM005

Maximum support bracket diameter: ..... 1200 mm / 47,2"  
 Weight: ..... 3,2 Kg / 7 lbs

10 **SA** Ref. SM006

Support bracket "side mounting"  
 Weight: ..... 0,7 Kg / 1,5 lbs

# GigamiX



Variable speed control  
0 to 4000 R.P.M.  
(sold separately)



01 02

## Mixer accessory



## Whip accessory



01 **Giraffe "Gigamix"**  
detachable 570 mm / 22,4" Ref. TB001

02 **Giraffe "Gigamix" with variable speed control**  
detachable 570 mm / 22,4" Ref. TB002

### Electrical specifications:

Voltage:..... 230 / 400 V, **3- phase**, 50 Hz  
Power output:..... 2,2 kW  
Speed (loaded):..... 4000 R.P.M.  
Thermal magnetic circuit breaker

### Technical specifications:

Mixer attachment only:..... 570 mm / 22,4"  
Diameter of mixer head:..... 270 mm / 10,6"

Overall dimensions: .95 cm x 60 cm x 170 cm / 37,5" x 24" x 67"  
Extended: ..... 170 cm x 60 cm x 120 cm / 67" x 24" x 47"  
Weight: ..... 79 Kg / 174 lbs

Minimum height: ..... 500 mm / 19,7"  
Maximum height extended: ..... 790 mm / 31"  
= amplitude: ..... 290 mm / 11,4"

03 **Whip accessory**  
Length: 300 mm / 11,8" Ref. TB003

This new Gigamix whip is ideal for delicate recipes, dehydrated soups... It provides the ultimate in mixing flexibility.  
**Gigamix whip attachment requires the variable speed base option.**



25 / 80 gal.



## Super mixer for large capacity applications

The Giraffe is designed for high volume, heavy duty mixing. Stainless steel construction offers many years of hygienic, uninterrupted food preparations. Constructed with heavy duty locking castors and tilting mechanism that allows for easy transport, safe and secure operation and convenient storage.

- Distance between frame and mixer shaft assembly: 800 mm / 31,5"
- Distance between bottom of mixer head and floor: minimum = 500 mm / 19,7" maximum = 790 mm / 31"
- Diameter of the wheels: 120 mm / 4,7"



## Professional Manual Salad spinner series

### Advantages:

- The Original
- Robust, fast
- High volume
- Watertight



Scan QR code with your smartphone to view  
SALAD SPINNER series demo videos



## SALAD SPINNER

Copied but unrivalled! Dynamic is the inventor of the commercial salad spinner. Quick and efficient, manual or electric. It is a necessity for the following reasons:  
 1- The drier the lettuce is, the longer the lettuce will last.  
 2- Dressing clings to dry lettuce with no run-off effect.  
 Both important food cost issues.



2,5 gal.



01



02



5 gal.



**The Original !**



**01 E 10 Manual salad spinner** Ref. E001

Diameter: ..... 330 mm / 13"  
 Total height: ..... 420 mm / 16,5"  
 Actual weight / shipping weight: 2,4 Kg / 5,3 lbs - 3,1 Kg / 6,8 lbs

Recommended capacity: 2 or 3 lettuce heads.

**02 E 20 Manual salad spinner** Ref. E002

Diameter: ..... 430 mm / 16,9"  
 Total height: ..... 500 mm / 19,7"  
 Actual weight / shipping weight: 3,6 Kg / 7,9 lbs - 4,8 Kg / 10,5 lbs

Recommended capacity: 3 or 5 lettuce heads.

**03 E 20 SC manual "sealed cover"** Ref. E004

Diameter: ..... 430 mm / 16,9"  
 Total height: ..... 500 mm / 19,7"  
 Actual weight / shipping weight: 3,6 Kg / 7,9 lbs - 4,8 Kg / 10,5 lbs

Recommended capacity: 3 or 5 lettuce heads.

**04 Stabilising base E20 & E20 SC** Ref. AC019

For E20, E20 SC and EM

Diameter: ..... 360 mm / 14,2"  
 Height: ..... 170 mm / 6,7"

**05 Set of gears - Complete set of gears**

**for both E10 - E20** Ref. 2815.1

**for E20 SC** Ref. 2815.2

**06 EM 98 electric salad spinner** Ref. E003

Total height: ..... 630 mm / 24,8"  
 Diameter: ..... 430 mm / 16,9"  
 Actual weight / shipping weight: 8,3 Kg / 18,3 lbs - 10 Kg / 22 lbs  
 Voltage: ..... 115 V or 230 V  
 Output max: ..... 200 W  
 Speed: ..... 500 R.P.M.

Recommended capacity: 3 or 5 lettuce heads.



**HACCP**

**Sealed cover**

5 gal.

03



04



5 gal.

06

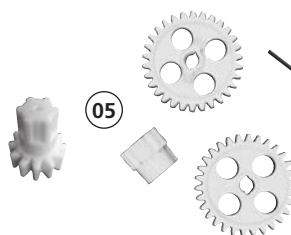

05



## Professional Manual food cutter series

### Advantages:

- Consistent cut
- Easy maintenance, durability
- Easily transportable
- Safe



Scan QR code with your smartphone to view  
DYNACOUBE series demo videos



Scan QR code with your smartphone to view  
DYNACUBE series demo videos



## FOOD CUTTER series CE

Slice and shred with ease. The Dynacoupe is ideal for manually slicing and shredding vegetables. This unit is easy to clean and the discs are easily interchangeable.



### 01 Dynacoupe without discs Ref. CL001

Total height: ..... 260 mm / 10,2"  
 Diameter: ..... 370 mm / 14,5"  
 Actual weight / shipping weight: . 2,1 Kg / 4,6 lbs - 2,8 Kg / 6,2 lbs

Very simple and easy to use, ideal for quickly and efficiently slicing and shredding vegetables. Discs sold separately.

### Dynacoupe with 2 discs Ref. CL002

Slicing disc: ..... thickness 3 mm / 1/8"  
 Shredding disc: ..... holes 3 mm / 1/8"

### Additional discs available

#### 02 SLICING DISCS

Thickness - 1,5 mm x Ø 220 mm - 1/64"	Ref. AC015
Thickness - 2 mm x Ø 220 mm - 5/64"	Ref. AC012
Thickness - 3 mm x Ø 220 mm - 1/8"	Ref. AC013
Thickness - 5 mm x Ø 220 mm - 3/16"	Ref. AC014

#### 03 SHREDDING DISCS

Ø holes - 2 mm x Ø 220 mm - 5/64"	Ref. AC020
Ø holes - 3 mm x Ø 220 mm - 1/8"	Ref. AC021
Ø holes - 4 mm x Ø 220 mm - 5/32"	Ref. AC022

### 04 Storage rack Ref. AC025

A 6-disc-capacity storage rack.



Food which needs to be shredded or sliced is inserted into the feeder. After placing an empty container below the unit, turn the handle and lightly apply pressure on the pusher which ensures total safety during operation.

Very simple and easy to use.  
**For the Dynacoupe**, just select and lock the disc in the slot and your unit is ready to use.

The Dynacoupe offers easy and simple cleaning and maintenance; following each use, simply remove the components. Hand wash with mild soap and rinse with warm water.

The Dynacoupe is supplied with 2 types of mounting supports:  
 ✓ Fixed supports for permanent installation.  
 ✓ Suction cups for temporary use. Designed to adapt perfectly to your working area.



# FOOD CUTTER



The perfect manual kitchen tool: simple and practical to use for rapidly and efficiently dicing vegetables. Its patented grid system made with surgical stainless steel blades, ensures a clean consistent cut of vegetables, fruit and some cooked meats. Great for soft vegetables.

## Dynacube allows 3 types of preparation:

- 1) For dicing use both grids and bottom cutter blade.
- 2) For sticks use both grids and remove bottom cutter blade
- 3) For slicing use the upper grid only.



05 Dynacube complete	*see ref. below
Complete Dynacube equipped with blade set 7 mm x 7 mm / 1/8" (Yellow grid set with pusher)	Ref. CL005*
Complete Dynacube equipped with blade set 8,5 mm x 8,5 mm / 1/4" (Orange grid set with pusher)	Ref. CL003*
Complete Dynacube equipped with blade set 10 mm x 10 mm / 3/8" (Red grid set with pusher)	Ref. CL006*
Complete Dynacube equipped with blade set 14 mm x 14 mm / 1/2" (Yellow grid set with pusher)	Ref. CL008*
Complete Dynacube equipped with blade set 17 mm x 17 mm / 3/4" (Orange grid set with pusher)	Ref. CL009*

Additional grid set	*see ref. below
Grid set 7 x 7mm / 1/8"	Ref. AC060*
Grid set 8,5 x 8,5mm / 1/4"	Ref. AC061*
Grid set 10 x 10mm / 3/8"	Ref. AC062*
Grid set 14 x 14mm / 1/2"	Ref. AC063*
Grid set 17 x 17mm / 3/4"	Ref. AC064*

Total height: ..... 330 mm / 13"  
 Diameter: ..... 400 mm / 15,7"  
 Weight / shipping weight: 3,1 Kg / 6,8 lbs - 4,4 Kg / 9,7 lbs



Food which needs to be shredded or sliced is inserted into the feeder. After placing an empty container below the unit, turn the handle and lightly apply pressure on the pusher which ensures total safety during operation.



Very simple and easy to use.  
**For the DynaCube**, unlatch the clips and remove the dome before allowing easy access to the grids. Re-install components, including lower cutter blade and the Dynacube is ready for use.



The Dynacube offers easy and simple cleaning and maintenance; following each use, simply remove the components. Hand wash with mild soap and rinse with warm water.



The Dynacube is supplied with 2 types of mounting supports:  
 ✓ Fixed supports for permanent installation.  
 ✓ Suction cups for temporary use. Designed to adapt perfectly to your working area.



# DYNACLIM



## An amazingly simple device !

The **Dynaclim**, refrigeration temperature and alarm controls.

- A 2-line + 2-screen-alphanumeric display board.
- 4, 8 or 16 zone measurements
- Temperature recording with unlimited timestamp registry on SD card.
- Single zone alarm on variable temperature change (up or down) as well as loss in power supply.
- Other alarm options available (i.e. walk-in door).
- Wireless signal compatible.
- Source: 230V / 50Hz
- PC compatible operating system. Easy and simple to program.
- Battery option 12V

*Complies with NF EN 12830 standards.*



<b>Dynaclim 4 zones*</b>	Ref. CE001
<b>Dynaclim 8 zones*</b>	Ref. CE002
<b>Dynaclim 16 zones*</b>	Ref. CE003
<b>Temperature probe (CTN 5K)</b>	Ref. CE004
<b>Source option: 230V</b>	Ref. CE005
<b>Optional GSM dialer</b>	Ref. CE006

(\*) supplied with 2 SD cards + operating system software

# DYNAJUICER



The **PA 96 Dynajuicer** is quiet and sturdy. It runs at 1500 R.P.M. and is great for juicing lemons, limes, oranges and grapefruit.

The cleaning of the unit takes less than 1 minute. All easy to clean components are manufactured of a sanitary material.



Scan QR code with your smartphone to view DYNAJUICER series demo videos



<b>Dynajuicer citrus juicer</b>	Ref. PA001
---------------------------------	------------

Total height:	330 mm / 13"
Diameter:	220 mm / 8,6"
Weight:	6,3 Kg / 13,9 lbs
Voltage:	115 V or 230 V
Output max:	200 W
Speed:	1500 R.P.M.

## MANUAL WHIP



01 **FMA 90** - Manual whip Ref. AC210

Capacity: ..... 20 / 200 litres  
 Length: ..... 1200 mm / 47,2"  
 Weight: ..... 1,1 Kg / 2,4 lbs

## MANUAL FOOD CUTTER CE



02 **CF 2000 Manual Food Cutter** Ref. CL004

Total height: ..... 560 mm / 22"  
 Total length: ..... 940 mm / 37"  
 Weight: ..... 8,3 Kg / 18,3 lbs  
 Plate: ..... 450 x 290 mm / 17,7" - 11,4"  
 Space between posts: ..... 320 mm / 12,6"  
 Space under blade: ..... 190 mm / 7,5"

**The Food cutter** can cut and slice various products which are awkward and difficult to cut with a knife, such as bread, cheese, pies and pizza. The operating lever system allows an effortless and perfect cut. The blade as well as the base can be taken apart for cleaning.

## ROADSIGN CONES

CE



**Roadsign cones** - Trilingual: English / Spanish / French.

03 **BS 50 W** Ref. BS001

Wet floor cones - Height 500 mm / 19,7"

03 **BS 75 W** Ref. BS004

Wet floor cones - Height 750 mm / 29,5"

04 **BS 50 S** Ref. BS003

No parking cones - Height 500 mm / 19,7"

04 **BS 75 S** Ref. BS006

No parking cones - Height 750 mm / 29,5"

## Dynamic, at the professionals' service for 50 years.



### Choosing the best material available ensures high quality Products.

Dynamic always takes great care in selecting the best material available for manufacturing. This ensures long and reliable years of product satisfaction.



### Custom made coiled motors.

Dynamic designs, manufactures and coils the inductors and motors which are used in the construction of mixers perfectly matching power and weight ratio on all of its machines.



### All product components manufactured within our facilities.

Dynamic offers a great aftersales service, close follow-up and renewal of our stocks. Close monitoring by our affiliates throughout the world assures reliability and availability of our entire range of products.

## Display rack

A practical and great way to visually display Dynamic products (please contact us for more information).



Counter display for catalogues.



## DVD

With this catalogue DVD, discover the complete DYNAMIC product line, including proper usage, care and cleaning procedures.



Available in black.

Dynamic and its products are environmentally friendly.



## Packaging

Dynamic's logo is displayed on all our packaging to assist at the point of sale and store display.



## Poster

Coloured poster displays our complete product line.



**WEEE (Directive on Waste Electrical and Electronic Equipment):**

Please contact your distributor.



Dynamic is a member of SYNEG (Syndicat National de l'Équipement des Grandes Cuisines)

# International distribution

## DYNAMIC'S SUBSIDIARY COMPANIES:

### NORTH AMERICAN DISTRIBUTION (USA / Canada)

Tel.: +1-800-267-7794 - +1-514-956-0127  
Fax: +1-877-668-6623 - +1-514-956-8983  
e-mail: info@dynamicmixers.com

#### • USA:

1320 route 9 # 1352 - Champlain, NY - 12919  
web: dynamicmixersusa.com

#### • CANADA: Montreal, Quebec

3227 Boul. pitfield  
H4S-1H3  
web: dynamicmixers.ca

### GERMANY

Eine starke Marke der Groupe NADIA GMBH  
Robert-Koch-Strasse 7 - 77694 Kehl  
Tel. +49 (0)7851 886 45-0  
Fax +49 (0)7851 886 45-32  
Kontakt: foodservice@groupe-nadia.de  
www.groupe-nadia.de

### SATELLITE OFFICES

TAHITI (Polynésie Française):  
Tel (689) 70 49 64



## GENERAL SALES CONDITIONS - EXTRACTS

Our goods are always carried at the buyer's risks, Whatever freight terms chosen, even "postage paid". Any claims have to be made within a delay of 72 hours after receipt of the goods. Each order is bound to our general sales conditions, which are the only ones valid.

Any impairment from the buyer's side, by whatever means, is not acceptable. Any tolerance from our company will not give any further rights. Our obligations will be suspended and our responsibility disengaged in case of major force or fortuitous cases. In case of nonperformance by the buyer of one of this obligations and 8 days after a formal notice by registered letter with acknowledgement of receipt, remaining ineffective, the sale is cancelled in full right, the goods have to be returned by the turner at his own expenses, without any prejudice of all other rights and resorts. In case of non-payment at the contractual due date, penalties for overdue payment equal to 3 times the legal interest rate will be due automatically and without formality, from the first day of delay. In addition, a lump sum allowance for costs of recovery representing an amount of 40 Euros will be due automatically and without formality. If the recovery costs are greater than this lump sum, complementary compensation will be due, upon presentation of supporting documents. Our drafts or acceptances are not subject of impairments as to the place of payment which is the head office of our company. In case of contestations, the commercial court, which our head office depends on, is the only competent one.

**PROPERTY CLAUSES:** The goods remain our property until the full settlement of the same. Settlement to be made in Mortagne-sur-Sèvre. In case of contestation the commercial court in La Roche-sur-Yon (France) is the only competent one.

**ORDERS:** Our prices are Ex-Works, packing included. Each order is subject to an acknowledgement of order with indication of prices, delivery time, and payment terms.

**RETURNS:** Goods will not be taken back or exchanged without our preliminary written agreement. In case of acceptation, 10 % of the returned goods value will be deduced for expenses. - Freight terms : Ex-Works.

**WARRANTY Dynamic:** Dynamic will guarantee all "new" DYNAMIC PRODUCTS to be free from defects in materials & workmanship. Electric products - Include a 1 year parts and labor carry in bench warranty with the exception of component replacements necessary through regular «wear & tear». Manual products - Include a 1 year limited parts warranty. Warranty is valid, providing the products have been used in accordance with Dynamic's operating recommendations & guidelines. DYNAMIC or any authorized service centres will repair or replace, at our discretion and after examination, any or all manufacturer's defective parts during the warranty period. Any damage caused by improper use, abuse, dropping, or similar accidental damage resulting in breakage will render the warranty null and void. During the warranty period, only DYNAMIC or one of its authorized service centres may perform evaluations or repairs to machines. Warranty will be void on any equipment which has been dismantled or tampered with during this warranty period if this has been done by unauthorized centres or personnel.

Distributed by:

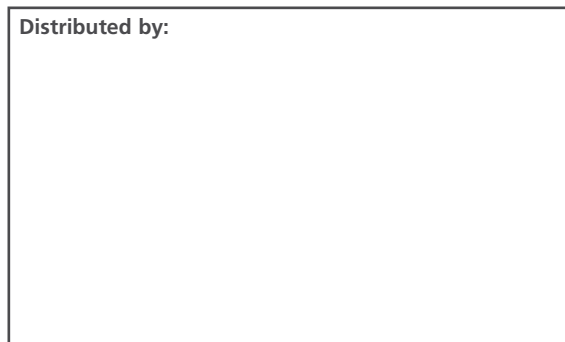

Please contact the nearest office  
for any additional information



## Dynamic FRANCE & EXPORT

RCS 416 450 435 La Roche sur Yon - S.A.S au capital de 216.780 €  
518 rue Baekeland - BP57 - 85290 Mortagne / Sèvre  
Tel. +33 (0)2 51 63 02 72 - Fax : +33 (0)2 51 63 02 73  
e-mail : contact@dynamicmixers.com  
www.dynamicmixers.com

